

Silicon NPN Planar RF Transistor

Description

The main purpose of this bipolar transistor is broadband amplification up to 2 GHz. In the space-saving 3-pin surface-mount SOT490 package electrical performance and reliability are taken to a new level covering a smaller footprint on PC boards than previous packages. In addition to space savings, the SOT490 provides a higher level of reliability than other 3-pin packages, such as more resistance to moisture. Due to the short length of its leads the SOT490 is also reducing package inductances resulting in some better electrical performance. All of these aspects make this device an ideal choice for demanding RF applications.

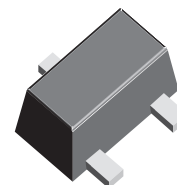
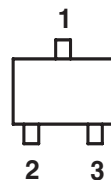

16867



Electrostatic sensitive device.
Observe precautions for handling.

Features

- Small feedback capacitance
- Low noise figure
- High power gain

Applications

For low noise and high gain broadband amplifiers at collector currents from 2 mA to 30 mA.

Mechanical Data

Typ: BFR183TF

Case: Plastic case (SOT 490)

Weight: 2.5 mg

Pinning: 1 = Collector, 2 = Base, 3 = Emitter

Parts Table

Part	Marking	Package
BFR183TF	RH	SOT490

Absolute Maximum Ratings

$T_{amb} = 25\text{ }^{\circ}\text{C}$, unless otherwise specified

Parameter	Test condition	Symbol	Value	Unit
Collector-base voltage		V_{CBO}	15	V
Collector-emitter voltage		V_{CEO}	10	V
Emitter-base voltage		V_{EBO}	2	V
Collector current		I_C	65	mA
Base current		I_B	5	mA
Total power dissipation	$T_{amb} \leq 60\text{ }^{\circ}\text{C}$	P_{tot}	200	mW
Junction temperature		T_j	150	$^{\circ}\text{C}$
Storage temperature range		T_{stg}	- 65 to + 150	$^{\circ}\text{C}$

Maximum Thermal Resistance

Parameter	Test condition	Symbol	Value	Unit
Junction ambient	¹⁾	R_{thJA}	450	K/W

¹⁾ on glass fibre printed board (25 x 20 x 1.5) mm³ plated with 35 μm Cu

Electrical DC Characteristics

$T_{amb} = 25\text{ }^{\circ}\text{C}$, unless otherwise specified

Parameter	Test condition	Symbol	Min	Typ.	Max	Unit
Collector cut-off current	$V_{CE} = 15\text{ V}, V_{BE} = 0$	I_{CES}			100	μA
Collector-base cut-off current	$V_{CB} = 10\text{ V}, I_E = 0$	I_{CBO}			100	nA
Emitter-base cut-off current	$V_{EB} = 1\text{ V}, I_C = 0$	I_{EBO}			1	μA
Collector-emitter breakdown voltage	$I_C = 1\text{ mA}, I_B = 0$	$V_{(BR)CEO}$	10			V
Collector-emitter saturation voltage	$I_C = 30\text{ mA}, I_B = 3\text{ mA}$	V_{CEsat}		0.1	0.4	V
DC forward current transfer ratio	$V_{CE} = 6\text{ V}, I_C = 5\text{ mA}$	h_{FE}	50	90	150	
	$V_{CE} = 8\text{ V}, I_C = 20\text{ mA}$	h_{FE}	50	110		

Electrical AC Characteristics

$T_{amb} = 25\text{ }^{\circ}\text{C}$, unless otherwise specified

Parameter	Test condition	Symbol	Min	Typ.	Max	Unit
Transition frequency	$V_{CE} = 8\text{ V}, I_C = 15\text{ mA}, f = 500\text{ MHz}$	f_T		7.2		GHz
	$V_{CE} = 8\text{ V}, I_C = 30\text{ mA}, f = 500\text{ MHz}$	f_T		7.5		GHz
Collector-base capacitance	$V_{CB} = 10\text{ V}, f = 1\text{ MHz}$	C_{cb}		0.4		pF
Collector-emitter capacitance	$V_{CE} = 8\text{ V}, f = 1\text{ MHz}$	C_{ce}		0.2		pF
Emitter-base capacitance	$V_{EB} = 0.5\text{ V}, f = 1\text{ MHz}$	C_{eb}		0.8		pF
Noise figure	$V_{CE} = 6\text{ V}, I_C = 5\text{ mA}, Z_S = 75\text{ }\Omega, f = 10\text{ MHz}$	F		0.9		dB
	$V_{CE} = 6\text{ V}, I_C = 5\text{ mA}, Z_S = Z_{Sopt}, f = 900\text{ MHz}$	F		1.1		dB
	$V_{CE} = 6\text{ V}, I_C = 5\text{ mA}, Z_S = Z_{Sopt}, f = 1.75\text{ GHz}$	F		1.7		dB
Power gain	$V_{CE} = 8\text{ V}, Z_S = 50\text{ }\Omega, Z_L = Z_{Lopt}, I_C = 30\text{ mA}, f = 900\text{ MHz}$	G_{pe}		15.5		dB
	$V_{CE} = 8\text{ V}, Z_S = 50\text{ }\Omega, Z_L = Z_{Lopt}, I_C = 30\text{ mA}, f = 1.75\text{ GHz}$	G_{pe}		11		dB
Transducer gain	$V_{CE} = 8\text{ V}, I_C = 30\text{ mA}, f = 900\text{ MHz}, Z_O = 50\text{ }\Omega$	$ S_{21e} ^2$		15		dB

Package Dimensions in mm or Inches (mm)

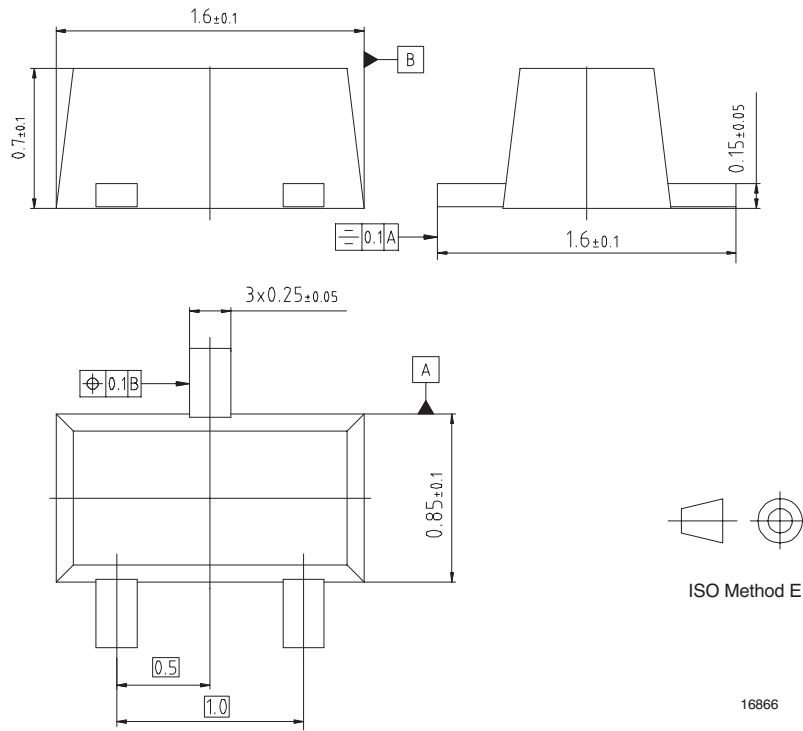

Ozone Depleting Substances Policy Statement

It is the policy of **Vishay Semiconductor GmbH** to

1. Meet all present and future national and international statutory requirements.
2. Regularly and continuously improve the performance of our products, processes, distribution and operating systems with respect to their impact on the health and safety of our employees and the public, as well as their impact on the environment.

It is particular concern to control or eliminate releases of those substances into the atmosphere which are known as ozone depleting substances (ODSs).

The Montreal Protocol (1987) and its London Amendments (1990) intend to severely restrict the use of ODSs and forbid their use within the next ten years. Various national and international initiatives are pressing for an earlier ban on these substances.

Vishay Semiconductor GmbH has been able to use its policy of continuous improvements to eliminate the use of ODSs listed in the following documents.

1. Annex A, B and list of transitional substances of the Montreal Protocol and the London Amendments respectively
2. Class I and II ozone depleting substances in the Clean Air Act Amendments of 1990 by the Environmental Protection Agency (EPA) in the USA
3. Council Decision 88/540/EEC and 91/690/EEC Annex A, B and C (transitional substances) respectively.

Vishay Semiconductor GmbH can certify that our semiconductors are not manufactured with ozone depleting substances and do not contain such substances.

We reserve the right to make changes to improve technical design and may do so without further notice.

Parameters can vary in different applications. All operating parameters must be validated for each customer application by the customer. Should the buyer use Vishay Semiconductors products for any unintended or unauthorized application, the buyer shall indemnify Vishay Semiconductors against all claims, costs, damages, and expenses, arising out of, directly or indirectly, any claim of personal damage, injury or death associated with such unintended or unauthorized use.

Vishay Semiconductor GmbH, P.O.B. 3535, D-74025 Heilbronn, Germany
Telephone: 49 (0)7131 67 2831, Fax number: 49 (0)7131 67 2423