

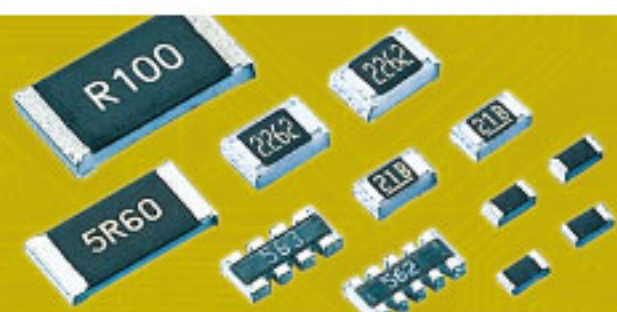

PSA

華新科技股份有限公司
Walsin Technology Corporation



Chip Resistors

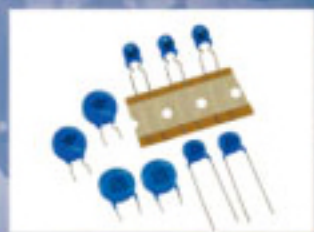

2011



Product Portfolio



Multilayer Ceramic Capacitors (MLCC)

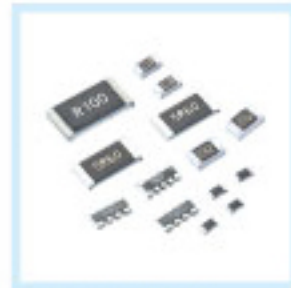

Chip-Resistor



Disc Capacitors



RF Device and High Frequency Inductors

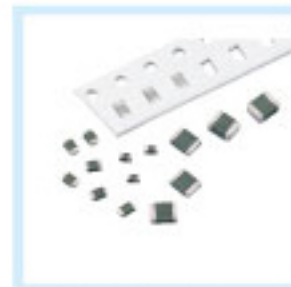

Varistors and SMD-Varistors

IEC-63 Nominal Resistance / Capacitance

E1	100																							
E3	100			220			470																	
E6	100	150	220	330	470	680																		
E12	100	120	150	180	220	270	330	390	470	560	680	820												
E24	100	110	120	130	150	160	180	200	220	240	270	300	330	360	390	430	470	510	560	620	680	750	820	910
E96	100	102	121	124	147	150	178	182	215	221	261	267	316	324	383	392	464	475	562	576	681	698	825	845
	105	107	127	130	154	158	187	191	226	232	274	280	332	340	402	412	487	499	590	604	715	732	866	887
	110	113	133	137	162	165	196	200	237	243	287	294	348	357	422	432	511	523	619	634	750	768	909	931
	115	118	140	143	169	174	205	210	249	255	301	309	365	374	442	453	536	549	649	665	787	806	953	976

E6: $\sqrt[6]{10} \approx 1.46$ E12: $\sqrt[12]{10} \approx 1.21$

E1 series resistance: 1Ω, 10Ω, 100Ω, 1000Ω, 10000Ω, 100000Ω

Subject	Page
How to Order	1
Chip Resistors Selection Guide.....	2~3
General Purpose Chip Resistors (1Ω~10MΩ).....	4
Thick Film Low Ohm /Power Low Ohm Chip Resistors (0.02Ω ~0.976Ω).....	5
Metal Low Ohm Sensing Chip Resistors (0.001Ω ~0.025Ω)	6
Chip Resistors Array : Convex Termination	7
WA06W Chip Resistors Array 16P8R	8
Chip Resistors Array : Concave Termination	9
WT04X Chip Resistors Network	10
WA04P Chip Attenuator	11
Special Chip Resistors	12
MR/SR Series of Automotive & Anti-Sulfuration Chip Resistors.....	12
WR_R Series of Total Lead Free Chip Resistors	12
WFxxM Series of Trimmable Chip Resistors	13
WFxxV Series of High Voltage Chip Resistors.....	13
WFxxP Series of High Power Chip Resistors.....	14
WFxxS Series of Surge Chip Resistors.....	15
High Precision Chip Resistors.....	15
Test and Requirements.....	16
Packing on Tape and Reel	17
Footprint Design	18
Storage and Handling Condition	19
Recommendation of Soldering Profile	19

Chip Resistors

www.passivecomponent.com

HOW TO ORDER

WR	06	X	1000	F	T	L
Type code WR: General 1~10MR MR: Automotive SR: Anti-Sulfuration	Size code 25 : 2512 (6432) 20 : 2010 (5025) 18 : 1218 (3248) 12 : 1206 (3216) 10 : 1210 (3225) 08 : 0805 (2012) 06 : 0603 (1608) 04 : 0402 (1005) 02 : 0201 (0603) 01 : 0100 (0402)	Functional code X : 5%: 1ohm ~ 10Mohm 1%: 10ohm ~ 1Mohm W : 1%: <10ohm ; >1Mohm F : 1% for <10ohm ; >1Mohm (TC100ppm)	Resistance E24(J tol.) : 2 significant digits followed by No. of zeros and a blank e.g. : 3ohm=3R0_ 10ohm=100_ 220ohm=221_ 56Kohm=563_ ("_" means blank) E24,E96(F tol.) : 3 significant digits followed by No. of zeros e.g.: 3ohm=3R00 10ohm=10R0 220ohm= 2200 56kohm = 5602	Tolerance F : +/- 1% J : +/- 5% P : Jumper	Packaging code P : 4" reel taping T : 7" reel taping A : 7" reel taping 15Kpcs Q : 10" reel taping G : 13" reel taping R : 0603 2mm pitch taping B : Bulk K : Bulkcase	Termination code L = Sn base (Lead free) R = Pb ≤ 100 ppm (total)
WW	25	M	R002	F	T	L
Type code WW: R< 1ohm MW: R< 1ohm Automotive SW: R< 1ohm Anti-sulfuration	Size code 25 : 2512 (6432) 20 : 2010 (5025) 18 : 1218 (3248) 12 : 1206 (3216) 10 : 1210 (3225) 08 : 0805 (2012) 06 : 0603 (1608) 04 : 0402 (1005)	Functional code X : Thick film low ohm M : Metal low ohm N : Metal low ohm, high power W : Thick film low TCR P : Thick film low TCR high power (2512 size=2 watt, 2010 size=1 watt, 1210 size=0.5 watt, 1206 size=0.5 watt,	Resistance "R" followed by 3 significant digits e.g. : 0.1ohm=R100 0.033ohm=R033 0.56ohm=R560	Tolerance F : +/- 1% G : +/- 2% J : +/- 5%	Packaging code P : 4" reel taping T : 7" reel taping Q : 10" reel taping G : 13" reel taping R : 0603 2mm pitch taping B : Bulk K : Bulkcase	Termination code L = Sn base (Lead free) G = Au base S = Ag base
WF	04	H	1001	B	T	L
Type code WF: Special function MF: Special function Automotive SF: Special function Anti-sulfuration	Size code 25 : 2512 (6432) 20 : 2010 (5025) 18 : 1218 (3248) 12 : 1206 (3216) 10 : 1210 (3225) 08 : 0805 (2012) 06 : 0603 (1608) 04 : 0402 (1005)	Functional code G : High ohmic (>10Mohm) H : Thick film, Precision tolerance<1% K : Thick film, TCR50ppm M : Trimmable P : High power S : Surge T : Thin film, TCR50ppm U : Thin film, TCR25ppm Q : Thin film TC50, power R : Thin film TC25, power W : Thin film TC10 F : Thin film TC15 V : High voltage X : Special resistance Y : E24/E96 resistance with special termination (non SnPb or Sn base), ≥1%	Resistance E24(J tol.) : 2 significant digits followed by No. of zeros and a blank e.g. : 3ohm=3R0_ 10ohm=100_ 220ohm=221_ 56Kohm=563_ ("_" means blank) E24,E96(F tol.) : 3 significant digits followed by No. of zeros e.g.: 3ohm=3R00 10ohm=10R0 220ohm= 2200 56kohm = 5602	Tolerance A : ±0.05% B : +/- 0.1% C : +/- 0.25% D : +/- 0.5% F : +/- 1% G : +/- 2% J : +/- 5% K : +/- 10% L : +/- 15% M : +/- 20% P : Jumper X : 0/-30% Y : 0/-20% Z : 0/-10%	Packaging code P : 4" reel taping T : 7" reel taping Q : 10" reel taping G : 13" reel taping R : 0603 2mm pitch taping B : Bulk K : Bulkcase	Termination code L = Sn base (Lead free) G = Au base S = Ag base
WA	04	Y	103_	J	T	L
Type code WA: Array MA: Array Automotive SA: Array Anti-sulfuration	Size code 06 : 0603 (1608) 04 : 0402 (1005)	Functional code X : *4, convex Y : *2, convex W : *8, convex T : *4, concave U : *2, concave P : *3, convex (Attenuator)	Resistance E24(J tol.) : 2 significant digits followed by No. of zeros and a blank e.g. : 3ohm=3R0_ 10ohm=100_ 220ohm=221_ 56Kohm=563_ ("_" means blank) E24,E96(F tol.) : 3 significant digits followed by No. of zeros	Tolerance F : +/- 1% J : +/- 5% P : Jumper	Packaging code T : 7" reel taping Q : 10" reel taping G : 13" reel taping B : Bulk K : Bulkcase	Termination code L = Sn base (Lead free)
WT	04	X	103_	J	T	L
Type code T: Network Resistors	Size code 04 : total package size 1206 (3216)	Functional code X : *8, convex	Resistance E24(J tol.) : 2 significant digits followed by No. of zeros and a blank e.g. : 3ohm=3R0_ 10ohm=100_ 220ohm=221_ 56Kohm=563_ ("_" means blank) E24,E96(F tol.) : 3 significant digits followed by No. of zeros	Tolerance J : +/- 5%	Packaging code T : 7" reel taping B : Bulk	Termination code L = Sn base (Lead free)

- Remark:** 1. Detail product part number, functional code, tolerance combination,...please refer to specific data sheet.
 2. Example: ("_" means blank)
 Chip-R 0805 size, 4.3ohm, 5% Normal type, Sn termination, 5000pcs taped in reel: WR08X4R3_JTL
 3. 1218 standard packing q'ty is 3Kpcs in 10" reel and packing code is "T code"

Chip Resistors

www.passivecomponent.com

■ Chip Resistors Selection Guide

■ General Purpose Chip-R

Series	Size	Rated Power	TCR (ppm/°C)	Tolerance	Resistance
WR02X	0201 (0603)	1/20W	200	±1%	1Ω ~ 10MΩ
			200	±5%	
WR04X	0402 (1005)	1/16W	100	±1%	
			200*	±5%	
WR06X	0603 (1608)	1/10W	100	±1%	
			200	±5%	
WR08X	0805 (2012)	1/8W	100	±1%	
			200	±5%	
WR12X	1206 (3216)	1/4W	100	±1%	
			200	±5%	
WR10X	1210 (3225)	1/3W	100	±1%	
			200	±5%	
WR18X	1218 (3248)	1W	100	±1%	
			200	±5%	
WR20X	2010 (5025)	1/2W	100	±1%	
			200	±5%	
WR25X	2512 (6432)	1W	100	±1%	
			200	±5%	

Remark : 1. Detailed resistance v.s. TCR and ordering code please refer to specific specifications.

2. Jumper resistor is not designed for fusing applications, designers shall apply dedicate fusible resistors or standard fuse in application circuits.

■ Thick Film Low Ohm Chip-R

Series	Size	Rated Power	TCR (ppm/°C)	Tolerance	Resistance	
WW25X	2512 (6432)	1W	≤1500**	±1%	0.020Ω ~ 0.976Ω	
				±5%	0.015Ω ~ 0.976Ω	
WW18X	1218 (3248)	1W		±1%	0.020Ω ~ 0.976Ω	
				±5%	0.015Ω ~ 0.976Ω	
WW20X	2010 (5025)	1/2W		±1%	0.020Ω ~ 0.976Ω	
				±5%	0.015Ω ~ 0.976Ω	
WW10X	1210 (3225)	1/3W		≤200	±1%	0.100Ω ~ 0.976Ω
				±5%	0.100Ω ~ 0.976Ω	
WW12X	1206 (3216)	1/4W		≤1500**	±1%	0.020Ω ~ 0.976Ω
				±5%	0.020Ω ~ 0.976Ω	
WW08X	0805 (2012)	1/8W	≤1500**	±1%	0.020Ω ~ 0.976Ω	
			±5%	0.020Ω ~ 0.976Ω		
WW06X	0603 (1608)	1/10W	≤500**	±1%	0.100Ω ~ 0.976Ω	
			±5%	0.100Ω ~ 0.976Ω		
WW04X	0402 (1005)	1/16W	≤600**	±1%	0.100Ω ~ 0.976Ω	
			±5%	0.100Ω ~ 0.976Ω		

Remark : 1. "****" Detail resistance v.s. TCR please refer to detailed specification.

2. Resistance value will be changed by soldering condition and design of soldering pad, please design products in consideration of this change of resistance value.

■ Thick Film Power Low Ohm Chip-R

Series	Size	Rated Power	TCR (ppm/°C)	Tolerance	Resistance
WW25P	2512 (6432)	2W	< 0.100ohm: 150ppm	±1%	0.047Ω ~ 0.976Ω
			≥ 0.100ohm: 100ppm	±5%	0.047Ω ~ 0.976Ω
WW20P	2010 (5025)	1W	< 0.100ohm: 150ppm	±1%	0.047Ω ~ 0.976Ω
			≥ 0.100ohm: 100ppm	±5%	0.047Ω ~ 0.976Ω
WW10P	1210 (3225)	1/2W	< 0.100ohm: 500ppm	±1%	0.020Ω ~ 0.976Ω
			≥ 0.100ohm: 200ppm	±5%	0.020Ω ~ 0.976Ω
WW12P	1206 (3216)	1/2W	< 0.100ohm: 200ppm	±1%	0.047Ω ~ 0.976Ω
			≥ 0.100ohm: 100ppm	±5%	0.047Ω ~ 0.976Ω
WW08P	0805 (2012)	1/3W	< 0.100ohm: 200ppm	±1%	0.047Ω ~ 0.976Ω
			≥ 0.100ohm: 150ppm	±5%	0.047Ω ~ 0.976Ω
WW06P	0603 (1608)	1/4W	< 0.100ohm: 250ppm	±1%	0.047Ω ~ 0.976Ω
			≥ 0.100ohm: 200ppm	±5%	0.047Ω ~ 0.976Ω
WW04P	0402 (1005)	1/8W	< 0.470ohm: 300ppm	±1%	0.100Ω ~ 0.976Ω
			≥ 0.470ohm: 200ppm	±5%	0.100Ω ~ 0.976Ω

■ Chip Attenuator

Series	Size	Type	Termination Type	Tolerance	Attenuation	Impedance
WA04P	0402x2 (1005x2)	4p3R, II type	Convex	±0.2db ~ 1dB	1dB ~ 10dB	50Ω

■ Metal Low Ohm Sensing Type Chip-R

Series	Size	Rated Power	TCR (ppm/°C)	Tolerance	Resistance
WW25M	2512 (6432)	1W	≤100	±1%, ±5%	1~ 50mΩ*
WW25N	2512 (6432)	2W	≤100	±1%, ±5%	1~ 25mΩ*
WW25Q	2512 (6432)	1W	≤100	±1%, ±5%	5, 10, 15mΩ
WW25R	2512 (6432)	2W	≤100	±1%, ±5%	1, 2, 3, 4, 5mΩ
WW20N	2010 (5025)	1W	≤75	±1%, ±5%	5, 10, 15, 20mΩ
WW12N	1206 (3216)	1W	≤70	±1%, ±5%	5, 10, 15, 20, 25mΩ
WW12R	1206 (3216)	1W	≤100	±1%, ±5%	5, 10, 15mΩ
WW06R	0603 (1608)	1/3W	≤100	±1%, ±5%	5, 10mΩ

Remark : Resistance value will be changed by soldering condition and design of soldering pad, please design products in consideration of this change of resistance value.

* Resistance range in detail specified in specification

For detailed resistance range, please refer to specification specified

■ Chip Resistors Array

Series	Size	Rated Power	TCR (ppm/°C)	Termination Type	Tolerance	Resistance
WA06X	1206 (0603x4)	1/10W	≤200	Convex	±1%, ±5%	10Ω ~ 1MΩ
WA06T	1206 (0603x4)	1/10W	≤200	Concave	±1%, ±5%	
WA06Y	0606 (0603x2)	1/10W	≤200	Convex	±1%, ±5%	
WA04X	0805 (0402x4)	1/16W	≤200	Convex	±1%, ±5%	
WA04Y	0404 (0402x2)	1/16W	≤300	Convex	±1%, ±5%	
WA04T	0805 (0402x4)	1/16W	≤300	Concave	±1%, ±5%	
WA04U	0404 (0402x2)	1/16W	≤300	Concave	±1%, ±5%	
WA06W	1606 (0602x8)	1/16W	≤200	Convex	±1%, ±5%	10Ω ~ 100KΩ

■ Chip Resistors Network

Series	Size	Rated Power	TCR (ppm/°C)	Termination Type	Tolerance	Resistance
WT04X	1206 (10P8R)	1/16W	≤200	Convex	±5%	10Ω ~ 100KΩ

■ Special Application Chip-R

Type	Series	Size	Rated Power	TCR (ppm/°C)	Tolerance	Resistance
High Power	WF25P	2512 (6432)	2W	≤ 100	±1%, ±5%	1Ω ~ 1MΩ
	WF20P	2010 (5025)	1W			
	WF10P	1210 (3225)	1/2W			
	WF12P	1206 (3216)	1/2W			
	WF08P	0805 (2012)	1/4W			
	WF06P	0603 (1608)	1/8W			
	WF04P	0402 (1005)	1/10W			
Automotive & Anti-Sulfuration	MR12X/SR12X	1206 (3216)	1/4W	≤ 200	±1%, ±5%	1Ω ~ 10MΩ
	MR08X/SR08X	0805 (2012)	1/8W			
	MR06X/SR06X	0603 (1608)	1/10W			
	MR04X/SR04X	0402 (1005)	1/16W			
Surge	WF25S	2512 (6432)	1W	≤ 100	±5%, ±10%, ±20%	1Ω ~ 1MΩ
	WF20S	2010 (5025)	1/2W			
	WF12S	1206 (3216)	1/4W			
High Voltage	WF25V	2512 (6432)	1W	≤ 200	±1%, ±5%	100KΩ ~ 10MΩ
	WF20V	2010 (5025)	1/2W			
	WF12V	1206 (3216)	1/4W			
High Precision	WF12H	1206 (3216)	1/4W	≤ 100	±0.1% ±0.5%	10Ω ~ 1MΩ
	WF08H	0805 (2012)	1/8W			
	WF06H	0603 (1608)	1/10W			
	WF04H	0402 (1005)	1/16W			
	WF12T	1206 (3216)	1/8W			
	WF08T	0805 (2012)	1/10W	≤ 50	±0.05% ±0.10% ±0.25% ±0.50% ±1.0%	10Ω ~ 1MΩ
	WF08Q		1/8W			10Ω ~ 1MΩ
	WF06T		1/16W			10Ω ~ 330KΩ
	WF06Q	0603 (1608)	1/10W	≤ 25	±0.05% ±0.10% ±0.25% ±0.50% ±1.0%	10Ω ~ 100KΩ
	WF04T	0402 (1005)	1/16W			10Ω ~ 100KΩ
	WF12U	1206 (3216)	1/8W			10Ω ~ 1MΩ
	WF08U	0805 (2012)	1/10W	≤ 15	±0.05% ±0.10%	10Ω ~ 1MΩ
	WF08R		1/8W			100Ω ~ 50KΩ
	WF06U	0603 (1608)	1/16W	≤ 10	±0.05% ±0.10%	10Ω ~ 330KΩ
	WF06R		1/10W			100Ω ~ 100KΩ
	WF04U	0402 (1005)	1/16W	100Ω ~ 100KΩ		
	WF08F	0805 (2012)	1/10W	100Ω ~ 100KΩ		
	WF06F	0603 (1608)	1/16W	100Ω ~ 50KΩ		
	WF08W	0805 (2012)	1/10W	100Ω ~ 100KΩ		
WF06W	0603 (1608)	1/16W	100Ω ~ 50KΩ			

Chip Resistors

www.passivecomponent.com

General Purpose Chip Resistors (1Ω~10MΩ)

Feature

1. High reliability and stability
2. Reduced size of final equipment
3. Lower assembly costs
4. Higher component and equipment reliability
5. RoHS compliant and lead free products

Description

The resistors are constructed in a high grade ceramic body (aluminum oxide). Internal metal electrodes are added at each end and connected by a resistive paste that is applied to the top surface of the substrate. The composition of the paste is adjusted to give the approximate resistance required and the value is trimmed to within tolerance by laser cutting of this resistive layer.

The resistive layer is covered with a protective coat. Finally, the two external end terminations are added. For ease of soldering the outer layer of these end terminations is Tin solder(Pb free) alloy.

Application

1. Consumer electrical equipment, PDA, Digital Camcorder, ...
2. EDP, Computer application
3. Mobile phone, Telecom
4. Power supply, Battery charger, DC-DC power converter
5. Digital meter
6. Automotives



Quick Reference Data

Series No.	WR25X	WR20X	WR18X	WR10X	WR12X	WR08X	WR06X	WR04X	WR02X
Size Code	2512 (6432)	2010 (5025)	1218(3248)	1210 (3225)	1206 (3216)	0805 (2012)	0603 (1608)	0402 (1005)	0201 (0603)
Resistance Range ±5% Tolerance (E24) ±1% Tolerance (E24+E96)	±5% (E24): 1Ω~10MΩ; Jumper ±1% (E24+E96): 1Ω~10MΩ								
TCR (ppm/°C) R > 1MΩ 1MΩ ≥ R ≥ 10 Ω R ≤ 10 Ω	≤ ± 200 ≤ ± 100 ≤ ± 200		≤ ± 200 ≤ ± 100 ≤ ± 200		≤ ± 200 ≤ ± 200*			≤ ± 200 ≤ ± 300	
Max. dissipation @ T _{amb} =70°C	1.0 Watt	1/2 Watt	1.0 Watt	1/3 Watt	1/4 Watt	1/8 Watt	1/10 Watt	1/16 Watt	1/20 Watt
Max. Operation Voltage (DC or RMS)	250V	200V	200V	200V	200V	150V	50V	50V	25V
Climatic category (IEC 60068)	55/155/56								55/125/56
Basic Specification	JIS C 5201-1 / IEC 60115-1								

Note :

1. This is the maximum voltage that may be continuously supplied to the resistor element, see "IEC publication 60115-8"
2. Max. Operation Voltage : So called RCWV (Rated Continuous Working Voltage) is determined by
 $RCWV = \sqrt{\text{Rater Power} \times \text{Resistance Value}}$ or Max. RCWV listed above, whichever is lower.
3. Detailed TCR please refer to specific specification.

Physical Dimensions

Unit: mm

Size	2512(6432)	2010(5025)	1218(3248)	1210(3225)	1206(3216)	0805(2012)	0603(1608)	0402(1005)	0201(0603)
L	6.40 ± 0.20	5.00 ± 0.20	3.05 ± 0.15	3.10 ± 0.10	3.10 ± 0.10	2.00 ± 0.10	1.60 ± 0.10	1.00 ± 0.05	0.60 ± 0.03
W	3.20 ± 0.20	2.50 ± 0.20	4.60 ± 0.20	2.60 ± 0.10	1.60 ± 0.10	1.25 ± 0.10	0.80 ± 0.10	0.50 ± 0.05	0.30 ± 0.03
T	0.60 ± 0.10	0.55 ± 0.10	0.55 ± 0.10	0.55 ± 0.10	0.60 ± 0.15	0.50 ± 0.15	0.45 ± 0.10	0.35 ± 0.05	0.23 ± 0.03
Tb	0.90 ± 0.25	0.60 ± 0.25	0.50 ± 0.25	0.50 ± 0.20	0.45 ± 0.20	0.40 ± 0.20	0.30 ± 0.15	0.25 ± 0.10	0.15 ± 0.05
Tt	0.65 ± 0.25	0.65 ± 0.25	0.45 ± 0.25	0.50 ± 0.20	0.50 ± 0.20	0.40 ± 0.20	0.30 ± 0.10	0.20 ± 0.10	0.10 ± 0.05

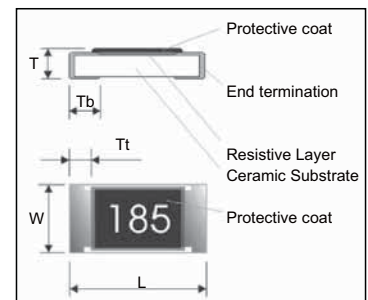

Power Deration Curve

For resistors operated in ambient temperature over 70°C, power rating should be derated in accordance with the following figures.

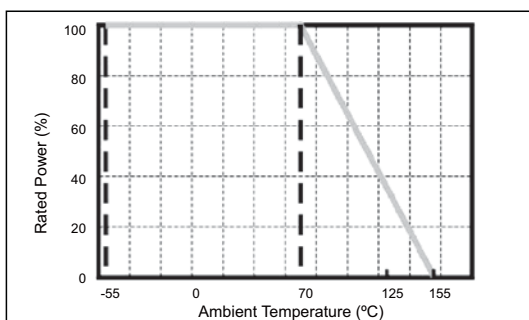

For Climatic category (IEC 60068) 55/155/56

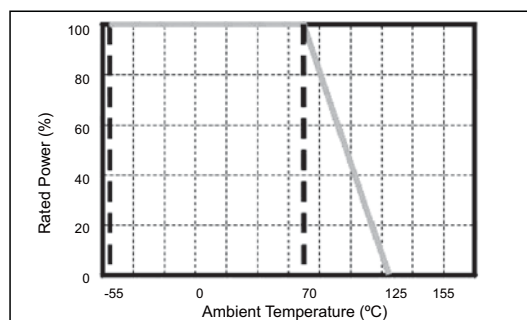

For Climatic category (IEC 60068) 55/125/56 (for 0201 type)

Thick Film Low Ohm/Power Low Ohm Chip Resistors

Function For Low Ohm Chip Resistors

The low ohmic resistors are used to sense output current in power supply, automotive and engine control management system, and other power sensing application. As shows in figure below, the typical function of low ohmic (power) chip resistor is to be a current sensor (R_{sense}) to generate the sensing voltage (V_s) for the purpose of feedback control when output current (I_o) passed on it. The sensing voltage be treated as a signal to trigger the switches (CMOS) ON/OFF duration so that to monitor and/or adjust the output current from inductor.

Simplify to say, $V_s = I_o \times R_{sense}$.

In general case, this feedback voltage is setting around 100mV for considering both on power saving and noise robustness. To sense a 5 ampere average output current, the R_{sense} resistance value therefore be required as $100mV / 5A = 20 m\Omega$, the power dissipation will be :

$$P = I^2 \times R = 5A^2 \times 20m\Omega = 0.5 \text{ Watt}$$

A low ohmic chip resistor with a power rating of 1.0 watt is recommended on this application in case the power safety margin is taken into account.

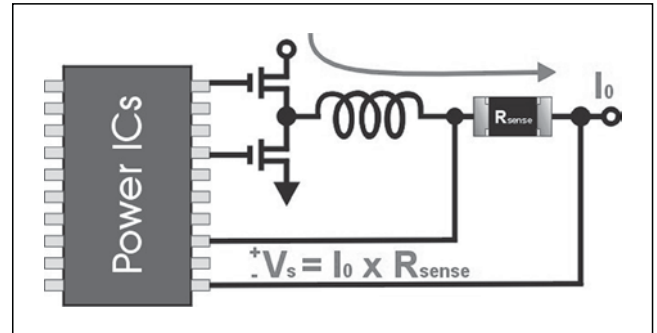

Quick Reference Data of Low Ohm Chip Resistor

Series No.	WW25X	WW20X	WW18X	WW10X	WW12X	WW08X	WW06X	WW04X
Size Code	2512 (6432)	2010 (5025)	1218(3248)	1210(3225)	1206 (3216)	0805 (2012)	0603 (1608)	0402 (1005)
Resistance Tolerance	±5%, ±1%							
Resistance Range	0.020Ω ~ 0.976Ω						0.100Ω ~ 0.976Ω	
TCR (ppm/°C)	Detailed TCR please refer to specific data sheets							
Max. dissipation @ $T_{amb}=70^{\circ}C$	1 Watt	0.5 Watt	1 Watt	1/3 Watt	1/4 Watt	1/8 Watt	1/10 Watt	1/16 Watt
Max. Operation Voltage (DC or RMS)	250V	200V	200V	200V	200V	100V	50V	50V
Climatic category (IEC 60068)	55/155/56							55/125/56
Basic Specification	JIS C 5201-1 / IEC 60115-1							

- Note :
1. This is the maximum voltage that may be continuously supplied to the resistor element, see "IEC publication 60115-8"
 2. Power derating curve, and detail specification please refer to specific data sheets.
 3. Resistance value will be changed by soldering condition and design of soldering pad, please design products in consideration of this change of resistance value.

Quick Reference Data of Power Low Ohm Chip Resistor

Item	General Specification				
Series No.	WW25P	WW20P	WW12P	WW08P	WW06P
Size code	2512 (6432)	2010 (5025)	1206 (3216)	0805 (2012)	0603 (1608)
Resistance Tolerance	± 1%, ± 5%				
Resistance Range	0.047 Ω ~ 0.976 Ω				
TCR (ppm/°C) < 0.100 Ω	±150 ppm/°C	±150 ppm/°C	±200 ppm/°C	±200 ppm/°C	±250 ppm/°C
≥ 0.100 Ω	±100 ppm/°C	±100 ppm/°C	±100 ppm/°C	±150 ppm/°C	±200 ppm/°C
Max. dissipation @ $T_{amb}=70^{\circ}C$	2W	1 W	1/2 W	1/3 W	1/4 W
Max. Operation Voltage (DC or RMS)	300V	200V	200V	150V	50V
Climatic category (IEC 60068)	55/155/56				

- Note:
1. This is the maximum voltage that may be continuously supplied to the resistor element, see "IEC publication 60115-8"
 2. Max. Operation Voltage : So called RCWV (Rated Continuous Working Voltage) is determined by $RCWV = \sqrt{\text{Rated Power} \times \text{Resistance Value}}$ or Max. RCWV listed above, whichever is lower.
 3. 2W loading with total solder-pad and trace size of 300 mm²

Physical Dimensions

Unit: mm

	WW25P	WW20P	WW12P	WW08P	WW06P
L	6.30 ± 0.20	5.00 ± 0.20	3.10 ± 0.15	2.00 ± 0.15	1.60 ± 0.10
W	3.10 ± 0.20	2.50 ± 0.20	1.60 ± 0.15	1.20 ± 0.15	0.80 ± 0.10
T	0.60 ± 0.15	0.60 ± 0.10	0.55 ± 0.10	0.50 ± 0.10	0.45 ± 0.10
Tt	0.60 ± 0.25	0.60 ± 0.25	0.50 ± 0.25	0.40 ± 0.20	0.30 ± 0.20
Tb	1.80 ± 0.25	0.60 ± 0.25	0.50 ± 0.25	0.40 ± 0.20	0.30 ± 0.20

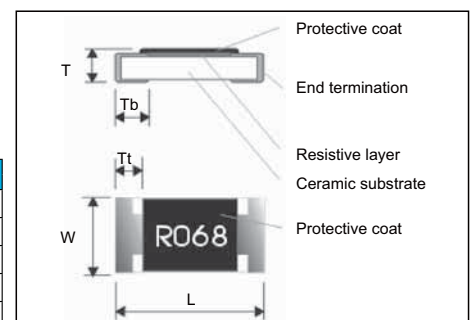

Chip Resistors

www.passivecomponent.com

■ Metal Low Ohm Sensing Chip Resistors (0.001Ω~0.025Ω)

■ Description

The resistors are constructed in a high grade low resistive metal body. The resistive layer is covered with a protective coat and printed a resistance marking code over it. Finally, the two external end terminations are added. For ease of soldering the outer layer of these end terminations is lead free terminations.

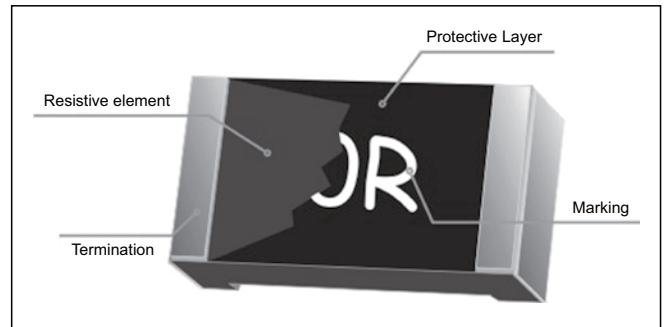

■ Quick Reference Data

Item	General Specification						
Series No.	WW25M		WW25N	WW20M	WW20N	WW12N	WW12M
Size code	2512 (6432)		2010 (5025)		1206 (3216)		
Resistance Tolerance	±5%, ±1%						
Resistance Range	1~10,12,15,20,25,30,40,50mΩ		1~10,12,15,20,25 mΩ		5,10,15,20mΩ		5,10,15,20,25mΩ
TCR (ppm/°C)	1-4mΩ: 100ppm; > 4mΩ: ≤ 75 ppm/°C		≤ 75 ppm/°C		≤ 70 ppm/°C		
Max. dissipation @ T _{amb} =70°C	1 W		2 W		1/2 W		1 W
Max. Operation Voltage (DC or RMS)	250V		250V		250V		200V
Max. Overload Voltage (DC or RMS)	500V		500V		500V		400V
Climatic category (IEC 60068)	55/155/56						

- Note :
1. This is the maximum voltage that may be continuously supplied to the resistor element, see "IEC publication 60115-8"
 2. Power derating curve, and detail specification please refer to specific data sheets.
 3. Resistance value will be changed by soldering condition and design of soldering pad, please design products in consideration of this change of resistance value.

■ Physical Dimensions:

WW25M(0.002Ω~0.025Ω), WW25N(0.003Ω~0.025Ω)

Unit: mm

Symbol	2512	2010	1206
L	6.40 ± 0.20	5.00 ± 0.20	3.10 ± 0.20
W	3.20 ± 0.20	2.50 ± 0.20	1.60 ± 0.20
T	0.60 ± 0.15	0.60 ± 0.15	0.60 ± 0.25
Tt	0.65 ± 0.25	0.65 ± 0.25	0.60 ± 0.20
Tb	0.65 ± 0.25	0.65 ± 0.25	0.60 ± 0.20

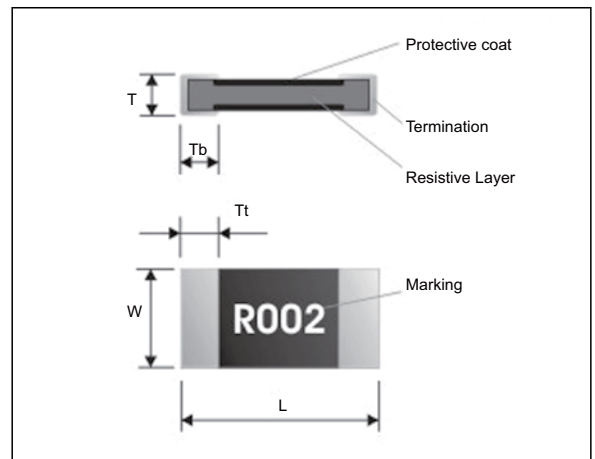

■ Physical Dimensions:

WW25M(0.001Ω), WW25N(0.001Ω~0.002Ω)

Unit: mm

Symbol	Dimensions
L	6.40 ± 0.20
W	3.20 ± 0.20
T	0.60 ± 0.10
Tt	1.60 ± 0.25
Tb	1.60 ± 0.25

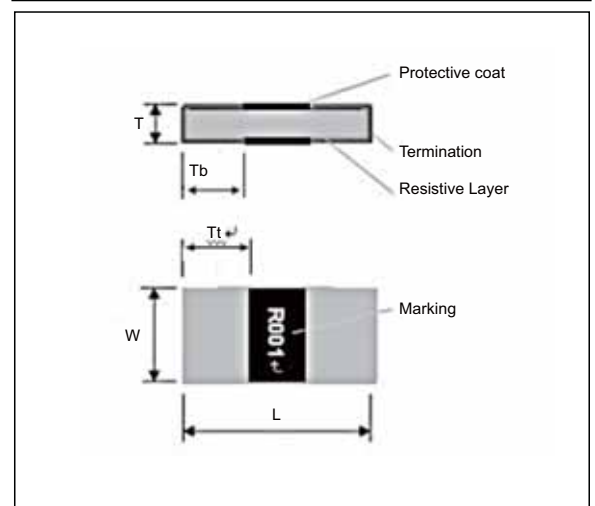

■ Chip Resistors Array : Convex Termination

■ Feature

1. High reliability and stability
2. Reduced size of final equipment
3. Lower assembly cost and higher surface mounted efficiency
4. Higher component and equipment reliability

■ Application

1. Consumer electrical equipment, PDA, Digital Camcorder, ...
2. EDP, Computer application
3. Mobile phone, Telecom
4. DIMM

■ Description and Physical Dimensions

The resistors array is constructed in a high grade ceramic body (aluminum oxide). Internal metal electrodes are added at each end and connected by a resistive paste that is applied to the top surface of the substrate. The composition of the paste is adjusted to give the approximate resistance required and the value is trimmed to within tolerance by laser cutting of this resistive layer.

The resistive layer is covered with a protective coat. Finally, the two external end terminations are added. For ease of soldering the outer layer of these end terminations is Tin solder alloy. Marking code description is depended on component size and tolerance. Following figure shown the construction of a Chip-R array.

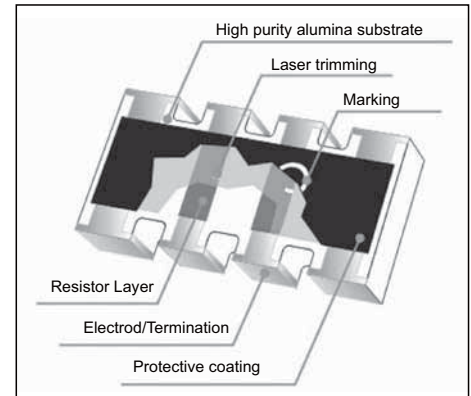

■ Physical Dimensions

Unit: mm

Type	WA06X	WA04X	WA06Y	WA04Y
L	3.20 ± 0.10	2.00 ± 0.10	1.60 ± 0.10	1.00 ± 0.10
W	1.60 ± 0.10	1.00 ± 0.10	1.50 ± 0.10	1.00 ± 0.10
T	0.50 ± 0.10	0.45 ± 0.10	0.50 ± 0.10	0.35 ± 0.10
P	0.80 ± 0.10	0.50 ± 0.05	1.00 ± 0.10	0.65 ± 0.10
A	0.60 ± 0.10	0.4 ± 0.10	0.60 ± 0.10	0.34 ± 0.10
B	0.30 ± 0.10	0.20 ± 0.10	0.30 ± 0.15	0.20 ± 0.15
C	0.40 ± 0.10	0.30 ± 0.05	-	-
G	0.30 ± 0.20	0.25 ± 0.10	0.30 ± 0.15	0.25 ± 0.17

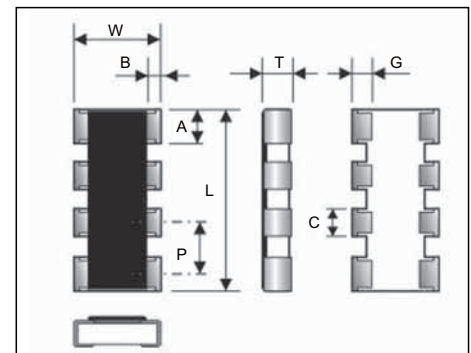

■ Quick Reference Data

Series No.	WA06X	WA04X	WA06Y	WA04Y
Size	0603x4 (1608x4)	0402x4 (1005x4)	0603x2 (1608x2)	0402x2 (1005x2)
Termination construction	8p4R, Convex	8p4R, Convex	4p2R, Convex	4p2R, Convex
Resistance Tolerance	±5% (E24 series)			
Resistance Range	10Ω ~ 1MΩ (E24 series), Jumper (0Ω)			
TCR (ppm/°C)	≤ ± 200 ppm/°C	≤ ± 200 ppm/°C	≤ ± 200 ppm/°C	≤ ± 300 ppm/°C
Max. dissipation @ T _{amb} =70°C	1/10 Watt	1/16 Watt	1/10 Watt	1/16 Watt
Max. Operation Voltage (DC or RMS)	50V	50V	50V	25V
Max. Overload Voltage (DC or RMS)	100V	100V	100V	50V
Climatic category (IEC 60068)	55/155/56			55/125/56
Basic Specification	JIS C 5201-1 / IEC 60115-1			
Circuit Mode: R1=R2(=R3=R4)				

Note :

1. Power derating curve, and detail specification please refer to specific data sheets.

Chip Resistors

www.passivecomponent.com

WA06W Chip Resistors Array 16P8R

Description

The resistors array is constructed in a high grade ceramic body (aluminum oxide). Internal metal electrodes are added at each end and connected by a resistive paste that is applied to the top surface of the substrate. The composition of the paste is adjusted to give the approximate resistance required and the value is trimmed to within tolerance by laser cutting of this resistive layer.

The resistive layer is covered with a protective coat. Finally, the two external end terminations are added. For ease of soldering the outer layer of these end terminations is Tin (Pb free) solder alloy.

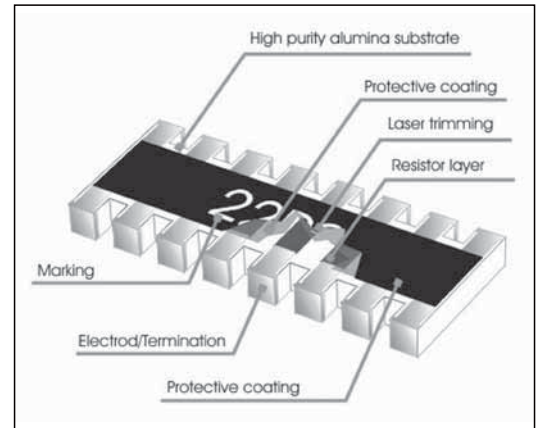

Quick Reference Data

Item	General Specification
Series No.	WA06W
Size	1606 (0602x8)
Termination construction	Convex type
Resistance Tolerance	±5% (E24 series)
Resistance Range	10Ω ~ 100KΩ, Jumper (0Ω)
TCR (ppm/°C)	≤ ± 200 ppm/°C
Max. dissipation @ T _{amb} =70°C	1/16 W
Max. Operation Voltage (DC or RMS)	50V
Max. Overload Voltage (DC or RMS)	100V
Climatic category (IEC 60068)	55/125/56
Circuit Mode	

Note :

1. Power derating curve, and detail specification please refer to specific data sheets.

Physical Dimensions

Unit: mm

Symbol	Dimensions
L	4.00 ± 0.20
W	1.60 ± 0.15
T	0.45 ± 0.10
B	0.30 ± 0.20
G	0.30 ± 0.20
D	0.20 ± 0.10
P	0.50 ± 0.20
H1	0.40 ± 0.20
H2	0.30 ± 0.10

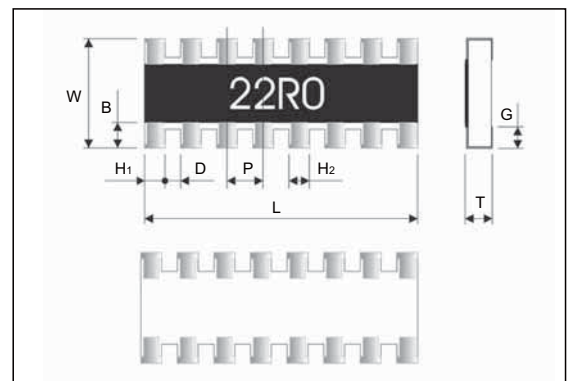

Chip Resistors Array : Concave Termination

Feature

1. High reliability and stability
2. Reduced size of final equipment
3. Lower assembly costs and higher surface mounted efficiency
4. Higher component and equipment reliability
5. Strong body and terminations
6. Excellence performance in surface mounting assembly.

Description and Physical Dimensions

The resistors array is constructed in a high grade ceramic body (aluminum oxide). Internal metal electrodes are added at each end and connected by a resistive paste that is applied to the top surface of the substrate. The composition of the paste is adjusted to give the approximate resistance required and the value is trimmed to within tolerance by laser cutting of this resistive layer.

The resistive layer is covered with a protective coat. Finally, the two external end terminations are added. For ease of soldering the outer layer of these end terminations is Tin solder alloy. Marking code description is depended on component size and tolerance. Following figure shown the construction of a Chip-R array.

Quick Reference Data

Item	General Specification	
Series No.	WA06T	WA04T
Size	0603x4 (1608x4)	0402x4 (1005x4)
Termination construction	Concave type	Concave type
Resistance Tolerance	±5% (E24 series)	±5% (E24 series)
Resistance Range	10Ω ~ 1MΩ, Jumper (0Ω)	10Ω ~ 1MΩ, Jumper (0Ω)
TCR (ppm/°C)	≤ ± 200 ppm/°C	≤ ± 300 ppm/°C
Max. dissipation @ T _{amb} =70°C	1/10 W	1/16 W
Max. Operation Voltage (DC or RMS)	50V	25V
Max. Overload Voltage	100V	50V
Climatic category (IEC 60068)	55/125/56	55/125/56

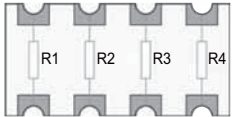
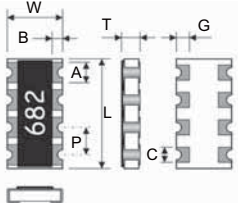
Circuit Mode			
	R1=R2=R3=R4		
	L	3.20 + 0.20/-0.10 mm	2.00 ± 0.10mm
	W	1.60 + 0.20/-0.10 mm	1.00 ± 0.10mm
	T	0.60 ± 0.20 mm	0.40 ± 0.10 mm
	P	0.80 ± 0.10 mm	0.50 ± 0.05mm
	A	0.60 ± 0.15 mm	0.35 ± 0.05 mm
	B	0.35 ± 0.15 mm	0.20 ± 0.15 mm
	C	0.50 ± 0.15mm	0.25 ± 0.05 mm
	G	0.50 ± 0.15 mm	0.25 ± 0.15mm

Note :

1. Power derating curve, and detail specification please refer to specific data sheets.
2. Lead Free (Pb free) products are available upon customer's request.

Quick Reference Data

Series No.	General Specification
Series No.	WA04U
Size	0402x2 (1005x2)
Termination construction	Concave type
Resistance Tolerance	±5%, ±1% (E24 series)
Resistance Range	10Ω ~ 1MΩ, Jumper (0Ω)
TCR (ppm/°C)	≤ ± 300 ppm/°C
Max. dissipation @ T _{amb} =70°C	1/16 W
Max. Operation Voltage (DC or RMS)	25V
Max. Overload Voltage	50V
Climatic category (IEC 60068)	55/155/56

Dimensions

	WA04U
L	1.00 ± 0.10
W	1.00 ± 0.10
T	0.30 ± 0.10
P	0.50 ± 0.05
A	0.35 ± 0.10
Ab	0.35 ± 0.10
B	0.25 ± 0.15
C	0.15 ± 0.10
D	0.25 ± 0.15

Unit: mm

Construction

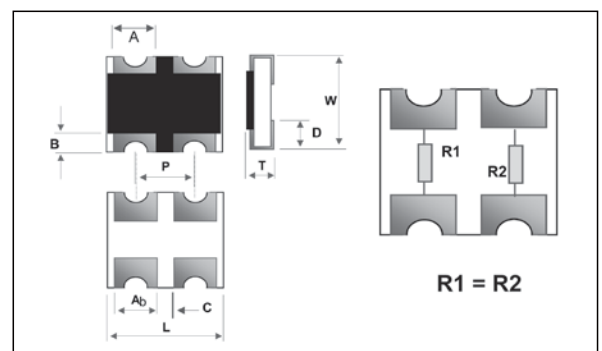

Note :

1. This is the maximum voltage that may be continuously supplied to the resistor element, see "IEC publication 60115-8"
2. Max. Operation Voltage : So called RCWV (Rated Continuous Working Voltage) is determined by
 $RCWV = \sqrt{\text{Rater Power} \times \text{Resistance Value}}$ or Max. RCWV listed above, whichever is lower.

Chip Resistors

www.passivecomponent.com

WT04X Chip Resistors Network

Description

The resistors array is constructed in a high grade ceramic body (aluminum oxide). Internal metal electrodes are added at each end and connected by a resistive paste that is applied to the top surface of the substrate. The composition of the paste is adjusted to give the approximate resistance required and the value is trimmed to within tolerance by laser cutting of this resistive layer.

The resistive layer is covered with a protective coat. Finally, the two external end terminations are added. For ease of soldering the outer layer of these end terminations is Tin solder (Pb free) alloy.

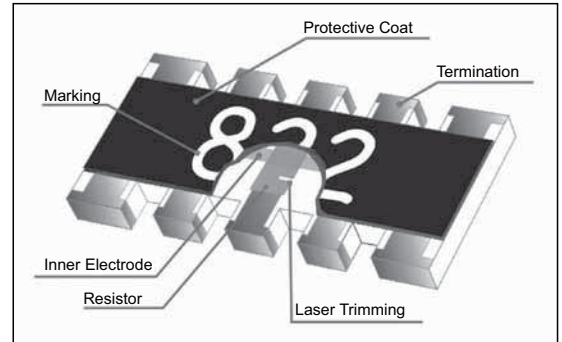

Quick Reference Data

Item	General Specification
Series No.	WT04X
Size	0402x8 (1005x8)
Termination construction	Convex type
Resistance Tolerance	±5% (E24 series)
Resistance Range	10Ω ~ 100KΩ
TCR (ppm/°C)	≤ ± 200 ppm/°C
Max. dissipation @ T _{amb} =70°C	1/16 Watt
Max. Operation Voltage (DC or RMS)	25V
Max. Overload Voltage	50V
Climatic category (IEC 60068)	55/155/56
Basic Specification	JIS C 5201-1/IEC 60115-1
Circuit Mode Resistor elements on pin1~pin4, pin6~pin9; R1=R2=R3=R4=R6=R7=R8=R9 pin5 and pin10 common (Grounded).	

Note :

1. Power derating curve, and detail specification please refer to specific data sheets.
2. Lead Free (Pb free) products are available upon customer's request.

Physical Dimensions

Unit: mm

	WT04X
L	3.30 ± 0.20
W	1.60 ± 0.15
T	0.55 ± 0.10
P	0.64 ± 0.05
A	0.50 ± 0.05
B	0.40 ± 0.15
C	0.40 ± 0.15
G	0.40 ± 0.15

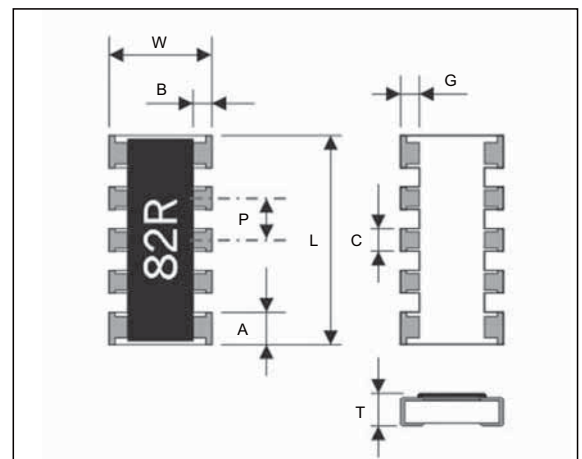

WA04P Chip Attenuator

Typical Application of Chip Attenuator

WA04	P	001	X	B	T	L
Size code WA04: 0402 per element	Type code P: convex, π type attenuator	Attenuation code 001=1dB 002=2dB 003=3dB 004=4dB 005=5dB 006=6dB 010=10dB	Tolerance X: 50 Ω	Rated voltage A: ± 0.2 dB B: ± 0.3 dB C: ± 0.5 dB D: ± 1.0 dB	Termination T=7" reel taped	Packaging L= Sn base (lead free)

π -Type Attenuator (-6dB, 50W) for VSWR improvement and output frequency level matching on VCO application.

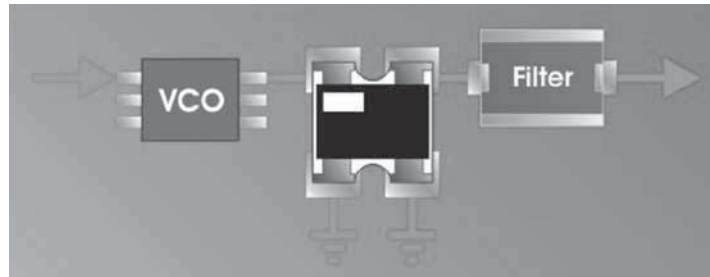

Quick Reference Data

Item	General Specification
Series No.	WA04P
Size	0402x3 (1005x3)
Termination construction	Convex type
Attenuation Range	1dB, 2dB, 3dB, 4dB, 5dB, 6dB, 7dB, 8dB, 9dB, 10dB
Attenuation Tolerance 1dB ~ 5dB	± 0.3 dB
6dB ~ 10dB	± 0.5 dB
Characteristic impedance	50 Ω
Rated power at $T_{amb}=70^{\circ}C$	0.04W / package
Limiting voltage (DC)	50V
Frequency range (DC)	Max. 2GHz
VSWR (Voltage Standing Wave Ratio)	Max. 1.3
Number of Resistors	3 resistors
Number of Terminals	4 terminals
Climatic category (IEC 60068)	55/125/56

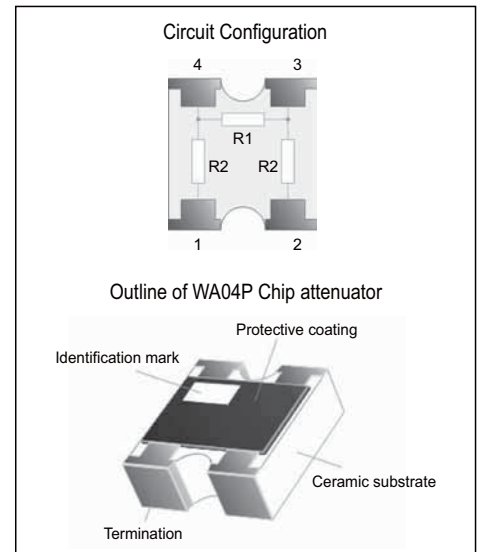

Physical Dimensions

Unit: mm

	WA04P
L	1.00 \pm 0.10
W	1.00 \pm 0.10
T	0.35 \pm 0.10
P	0.65 \pm 0.10
A	0.33 \pm 0.10
Ta	0.15 \pm 0.10
Tb	0.25 \pm 0.10

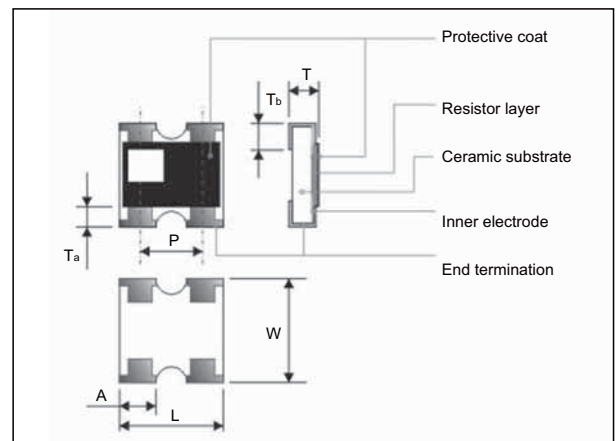

Chip Resistors

www.passivecomponent.com

Special Chip Resistors

Feature

1. Provided Automotive & Anti-sulfuration resistors (MR/SR series) for Auto & Anti-sulfuration application.
2. Provided Total Lead Free resistors (WR_R series) to fulfill RoHS environmental regulation.
3. Provided trimmable resistors (WFxxM series) for customer special tolerance requirement.
4. Provided high precision tolerance (WFxxH/ WFxxT/WFxxU/WFxxW) down to $\pm 0.05\%$ and TCR down to 10ppm/°C for voltage sensing application.
5. High reliability and stability
6. Reduced size of final equipment
7. Lower assembly costs
8. Higher component and equipment reliability.
9. Special resistance, tolerance are available upon customer's request.

MR/SR Series of Automotive & Anti-Sulfuration Chip Resistor

Feature

1. High reliability and stability $\pm 1\%$
2. Sulfuration resistant
3. Automotive grade AEC Q-200 compliant
4. 100% CCD inspection
5. RoHS compliant and lead free

Application

1. Automotive application
2. Consumer electrical equipment
3. EDP, Computer application
4. Telecom application

Quick Reference Data

Series No.	MR12X/SR12X	MR08X/SR08X	MR06X/SR06X	MR04X/SR04X
Size code	1206 (3216)	0805 (2012)	0603 (1608)	0402 (1005)
Resistance Range	1Ω -10MΩ ($\pm 1\%$, $\pm 5\%$), Jumper			
TCR (ppm/°C)	$\leq \pm 200$ ppm*			
Max. dissipation @ Tamb=70°C	1/4 W	1/8 W	1/10 W	1/16 W
Max. Operation Voltage (DC or RMS)	200V	150V	75V	50
Climatic category (IEC 60068)	55/155/56			

Remark: *Detail specification please refer to specific data sheets!

* MR series can withstand H₂S 3ppm x 1000 hrs

* SR series can withstand H₂S 1000ppm x 720 hrs

WR_R Series of Total Lead Free Chip Resistors

Feature

1. High reliability and stability
2. Reduced size of final equipment
3. Low assembly costs
4. Higher component and equipment reliability
5. RoHS compliant and total lead free

Quick Reference Data

Series No.	WR12_R	WR08_R	WR06_R	WR04_R
Size code	1206 (3216)	0805 (2012)	0603 (1608)	0402 (1005)
Resistance Range	1Ω -10MΩ ($\pm 1\%$, $\pm 5\%$), Jumper			
TCR (ppm/°C)	$\leq \pm 200$ ppm*			
Max. dissipation @ Tamb=70°C	1/4 W	1/8 W	1/10 W	1/16 W
Max. Operation Voltage (DC or RMS)	200V	150V	50V	50
Climatic category (IEC 60068)	55/155/56			

Remark: *Detail specification please refer to specific data sheets!

Part No. Definition

1 st code	2 nd code	3 rd ~ 4 th code	5 th code	6 th ~ 9 th code	10 th code	11 th code	12 th code
□	□	□□	□	□□□□	□	□	R
WTC	Type code	Size code	Functional code	Marking code (Resistance)	Tolerance code	Packaging code	Termination code
Example W	R	04	X	1000	F	T	R

WFxxM Series of Trimmable Chip Resistors

Feature

1. High precision, reliability and stability
2. Miniature size to 0603(1608)

Description

The resistors are constructed on a high-grade ceramic body (aluminum oxide). Internal metal electrodes are added at each end and connected by a resistive paste, which is applied to the substrate. The composition of the paste is adjusted to give the approximate resistance required. The resistive layer is converted with a transparent protective coating. Finally the two external end terminations are added. For case of soldering the outer of these end terminations is Tin solder (Pb free) alloy.

Physical Dimensions

Unit: mm

	WF20M	WF12M	WF08M	WF06M
L	5.00 ± 0.20	3.10 ± 0.10	2.00 ± 0.10	1.60 ± 0.10
W	2.50 ± 0.20	1.60 ± 0.10	1.25 ± 0.10	0.80 ± 0.10
T	0.55 ± 0.15	0.60 ± 0.15	0.50 ± 0.15	0.45 ± 0.15
Tb	0.65 ± 0.25	0.45 ± 0.20	0.40 ± 0.20	0.30 ± 0.20
Tt	0.60 ± 0.25	0.50 ± 0.20	0.40 ± 0.20	0.30 ± 0.10

Quick Reference Data

Series No.	WF20M	WF12M	WF08M	WF06M
Size code	2010 (5025)	1206 (3216)	0805 (2012)	0603 (1608)
Resistance Tolerance	0/-10%(Z), 0/-20%(Y) and 0/-30%(X) E24 series			
Resistance Range	1Ω ~ 10MΩ			
TCR (ppm/°C)	≥10Ω ≤ ± 200 ppm/°C <10Ω -300~+500 ppm/°C			
Max. dissipation @ T _{amb} =70°C	1/2 Watt	1/4 Watt	1/8 Watt	1/10 Watt
Max. Operation Voltage (DC or RMS)	200V	200V	100V	50V
Climatic category (IEC 60068)	55/125/56			
Basic Specification	JIS C 5201-1 / IEC 60115-1			

Application

1. Automotive application
2. Consumer electrical equipment
3. EDP, Computer application
4. Telecom application

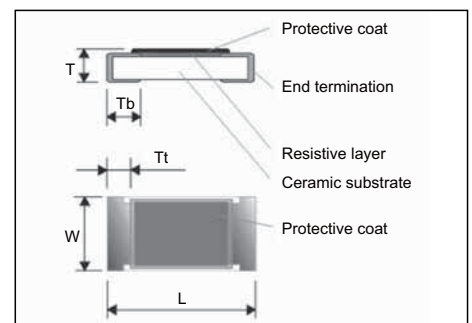
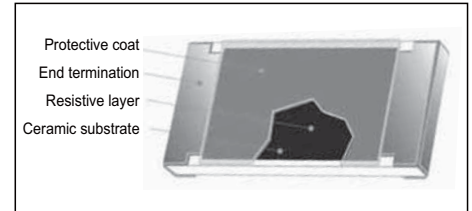

Trimming Conditions

Please refer to specific data sheet.

WFxxV Series of High Voltage Chip Resistors

Feature

1. Special material and design for high working voltage required
2. Compatible with flow and reflow soldering.
3. Suitable for lead free soldering.

Quick Reference Data

Item	General Specification		
	WF25V	WF20V	WF12V
Series No.	WF25V	WF20V	WF12V
Size code	2512 (6432)	2010 (5025)	1206 (3216)
Resistance Tolerance	± 5% ; ± 1%		
Resistance Range	100 KΩ ~ 10 MΩ		
TCR (ppm/°C)	± 200 ppm/°C		
Max. dissipation @ T _{amb} =70°C	1 W	1/2 W	1/4 W
Max. Operation Voltage (DC or RMS)	2000V	1500V	800V
Max. Overload Voltage (DC or RMS)	4000V	3000V	1600V
Climatic category (IEC 60068)	55/155/56		

Note:

1. This is the maximum voltage that may be continuously supplied to the resistor element, see "IEC publication 60115-8"
2. Max. Operation Voltage : So called RCWV (Rated Continuous Working Voltage) is determined by $RCWV = \sqrt{\text{Rated Power} \times \text{Resistance Value}}$ or Max. RCWV listed above, whichever is lower.

Physical Dimensions

Unit: mm

Symbol	WF25V	WF20V	WF12V
L	6.30 ± 0.20	5.00 ± 0.20	3.10 ± 0.15
W	3.10 ± 0.20	2.50 ± 0.20	1.60 ± 0.15
T	0.60 ± 0.15	0.60 ± 0.10	0.55 ± 0.10
Tt	0.60 ± 0.25	0.60 ± 0.25	0.50 ± 0.25
Tb	0.90 ± 0.25	0.60 ± 0.25	0.50 ± 0.25

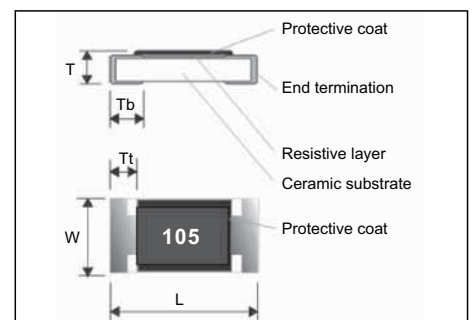

Chip Resistors

www.passivecomponent.com

WFxxP Series of High Power Chip Resistors

Feature

1. High power rating and compact size
2. High reliability and stability
3. Reduced size of final equipment
4. Lead free product is upon customer requested.

Quick Reference Data

Item	General Specification				
Series No.	WF25P	WF20P	WF12P	WF08P	WF06P
Size code	2512 (6432)	2010 (5025)	1206 (3216)	0805 (2012)	0603 (1608)
Resistance Tolerance	± 1%, ± 5%			± 1%	± 5%
Resistance Range	0 Ω, 1 Ω ~ 1 MΩ				
TCR (ppm/°C)	± 100 ppm/°C				
Max. dissipation @ T _{amb} =70°C	2W	1 W	1/2 W	1/4 W	1/8 W
Max. Operation Voltage (DC or RMS)	300V	200V	200V	150V	50V
Climatic category (IEC 60068)	55/155/56				

Note:

1. This is the maximum voltage that may be continuously supplied to the resistor element, see "IEC publication 60115-8"
2. Max. Operation Voltage : So called RCWV (Rated Continuous Working Voltage) is determined by $RCWV = \sqrt{\text{Rated Power} \times \text{Resistance Value}}$ or Max. RCWV listed above, whichever is lower.
3. 2W loading with total solder-pad and trace size of 300 mm²
4. 0Ω maximum resistance R_{max} < 15mΩ and rated current < 4Amp

Physical Dimensions

Unit: mm

	WF25P	WF20P	WF12P	WF08P	WF06P
L	6.30 ± 0.20	5.00 ± 0.20	3.10 ± 0.15	2.00 ± 0.15	1.60 ± 0.10
W	3.10 ± 0.20	2.50 ± 0.20	1.60 ± 0.15	1.20 ± 0.15	0.80 ± 0.10
T	0.60 ± 0.15	0.60 ± 0.10	0.55 ± 0.10	0.50 ± 0.10	0.45 ± 0.10
T _t	0.60 ± 0.25	0.60 ± 0.25	0.50 ± 0.25	0.40 ± 0.20	0.30 ± 0.20
T _b	1.80 ± 0.25	0.60 ± 0.25	0.50 ± 0.25	0.40 ± 0.20	0.30 ± 0.20

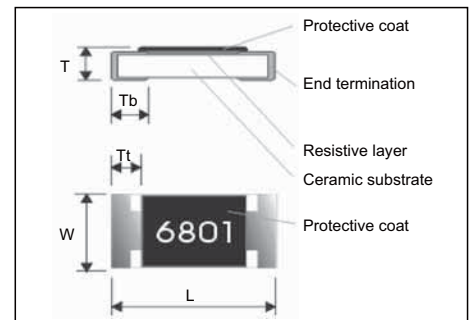

WFxxS Series of Surge Chip Resistors

Feature

1. Power rating and compact size
2. High reliability and stability
3. Reduced size of final equipment
4. Surge protection

Quick Reference Data

Item	General Specification		
Series No.	WF25S	WF20S	WF12S
Size code	2512 (6432)	2010 (5025)	1206 (3216)
Resistance Tolerance	±5%, ±10%, ±20%, (E24)		
Resistance Range	10Ω ~ 1MΩ		
TCR (ppm/°C)	± 100 ppm/°C		
Max. dissipation @ T _{amb} =70°C	1 W	1/2 W	1/4 W
Max. Operation Voltage (DC or RMS)	200V	200V	200V
Max. Overload Voltage (DC or RMS)	400V	400V	400V
Climatic category (IEC 60068)	55/125/56		

Note:

1. This is the maximum voltage that may be continuously supplied to the resistor element, see "IEC publication 60115-8"
2. Max. Operation Voltage : So called RCWV (Rated Continuous Working Voltage) is determined by $RCWV = \sqrt{\text{Rated Power} \times \text{Resistance Value}}$ or Max. RCWV listed above, whichever is lower.

Physical Dimensions

Unit: mm

	WF25S	WF20S	WF12S
L	6.30 ± 0.20	5.00 ± 0.20	3.10 ± 0.15
W	3.10 ± 0.20	2.50 ± 0.20	1.60 ± 0.15
T	0.60 ± 0.15	0.60 ± 0.10	0.55 ± 0.10
T _t	0.60 ± 0.25	0.60 ± 0.25	0.50 ± 0.25
T _b	0.60 ± 0.25	0.60 ± 0.25	0.50 ± 0.25

Application

1. Power supply
2. Measurement instrument
3. Automotive industry
4. Medical or Military equipment

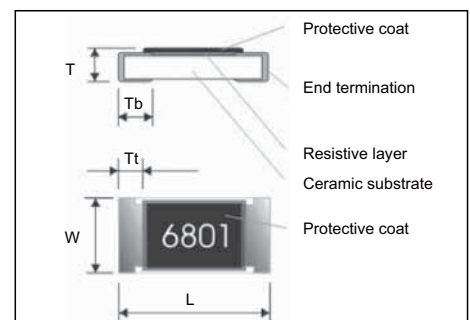
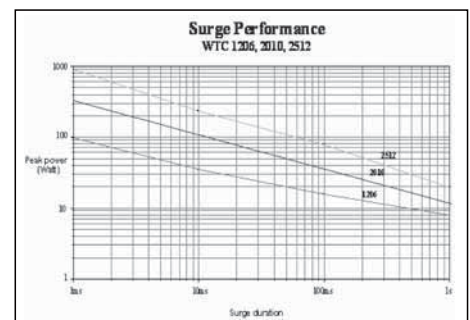

High Precision Chip Resistors

Narrow Tolerance Thick Film TC100 WFxxH Series

Quick Reference Data

Series No.	WF12H	WF08H	WF06H	WF04H
Size code	1206 (3216)	0805 (2012)	0603 (1608)	0402 (1005)
Resistance Tolerance	±0.5%, ±0.1%			
Resistance Range	10Ω ~ 1MΩ (E96+E24 series)			
TCR (ppm/°C) 10MΩ≤R≤1MΩ	≤ ± 100 ppm/°C			≤ ± 200 ppm/°C
Max. dissipation @ T _{amb} =70°C	1/4 Watt	1/8 Watt	1/10 Watt	1/16 Watt
Max. Operation Voltage (DC or RMS)	200V	100V	50V	50V
Climatic category (IEC 60068)	55/155/56			
Basic Specification	JIS C 5201-1 / IEC 60115-1			

(Detail specification please refer to specific data sheets)

Narrow Tolerance Thin Film TC50 WFxxT Series

Quick Reference Data

Series No.	WF12T	WF08T	WF06T	WF04T	WF08Q	WF06Q
Size code	1206 (3216)	0805 (2012)	0603 (1608)	0402 (1005)	0805 (2012)	0603 (1608)
Resistance Tolerance	±0.5%, ±0.1%					
TCR (ppm/°C)	≤ ± 50 ppm/°C					
Max. dissipation @ T _{amb} =70°C	1/8 Watt	1/10 Watt	1/16 Watt	1/16 Watt	1/8 Watt	1/10 Watt
Max. Operation Voltage (DC or RMS)	200V	100V	50V	50V	150V	50V
Climatic category (IEC 60068)	55/125/56					
Basic Specification	JIS C 5201-1 / IEC 60115-1					

(Detail specification please refer to specific data sheets)

Narrow Tolerance Thin Film TC25 WFxxU Series

Quick Reference Data

Series No.	WF12U	WF08U	WF06U	WF04U	WF08R	WF06R
Size code	1206 (3216)	0805 (2012)	0603 (1608)	0402 (1005)	0805 (2012)	0603 (1608)
Resistance Tolerance	±0.5%, ±0.1%, ±0.05%					
TCR (ppm/°C)	≤ ± 25 ppm/°C					
Max. dissipation @ T _{amb} =70°C	1/8 Watt	1/10 Watt	1/16 Watt	1/16 Watt	1/8 Watt	1/10 Watt
Max. Operation Voltage (DC or RMS)	200V	100V	50V	50V	150V	50V
Climatic category (IEC 60068)	55/125/56					
Basic Specification	JIS C 5201-1 / IEC 60115-1					

(Detail specification please refer to specific data sheets)

Narrow Tolerance Thin Film TC15 WFxxF Series

Series No.	WF12F*	WF08F	WF06F	WF04F*
Size code	1206 (3216)	0805 (2012)	0603 (1608)	0402 (1005)
Resistance Tolerance	±0.5%, ±0.1%, ±0.05%			
TCR (ppm/°C)	≤ ± 10 ppm/°C			
Max. dissipation @ T _{amb} =70°C	1/8 Watt	1/10 Watt	1/16 Watt	1/16 Watt
Max. Operation Voltage (DC or RMS)	200V	100V	50V	50V
Climatic category (IEC 60068)	55/125/56			
Basic Specification	JIS C 5201-1 / IEC 60115-1			

(Detail specification please refer to specific data sheets)

* Sample is available upon request

Narrow Tolerance Thin Film TC10 WFxxW Series

Series No.	WF12W*	WF08W	WF06W	WF04W*
Size code	1206 (3216)	0805 (2012)	0603 (1608)	0402 (1005)
Resistance Tolerance	±0.5%, ±0.1%, ±0.05%			
TCR (ppm/°C)	≤ ± 10 ppm/°C			
Max. dissipation @ T _{amb} =70°C	1/8 Watt	1/10 Watt	1/16 Watt	1/16 Watt
Max. Operation Voltage (DC or RMS)	200V	100V	50V	50V
Climatic category (IEC 60068)	55/125/56			
Basic Specification	JIS C 5201-1 / IEC 60115-1			

(Detail specification please refer to specific data sheets)

* Sample is available upon request

Chip Resistors

www.passivecomponent.com

■ Test and Requirements

■ For WR Series, WA Series, and WT Series

Test	Procedure / Test Method	Requirements	
		Resistor	0Ω
Electrical Characteristics JISC5201-1: 1998 Clause 4.8	- DC resistance values measurement - Temperature Coefficient of Resistance (T.C.R) Natural resistance change per change in degree centigrade. $\frac{R_2 - R_1}{R_1 (t_2 - t_1)} \times 10^6$ (ppm/°C) t1 : 20°C+5°C-1°C R1 : Resistance at reference temperature (20°C+5°C-1°C) R2 : Resistance at test temperature (-55°C or +155°C)	Within the specified tolerance Refer to "QUICK REFERENCE DATA"	< 50m Ω
Resistance to soldering heat (R.S.H) JISC5201-1:1998 Clause 4.18	Un-mounted chips completely immersed for 10±1second in a SAC solder bath at 260°C±5°C	ΔR/R max. ±(1%+0.05Ω) no visible damage	< 50m Ω
Solderability JISC5201-1: 1998 Clause 4.17	Un-mounted chips completely immersed for 2±0.5 second in a SAC solder bath at 235°C±5°C	95% coverage min., good tinning and no visible damage	
Temperature cycling JISC5201-1: 1998 Clause 4.19	30 minutes at -55°C±3°C, 2~3 minutes at 20°C+5°C-1°C, 30 minutes at +155°C±3°C, 2~3 minutes at 20°C+5°C-1°C, total 5 continuous cycles	ΔR/R max. ±(1%+0.05Ω) no visible damage	< 50m Ω
High Temperature Exposure MIL-STD-202 method 108	1000+48/-0 hours; without load in a temperature chamber controlled 155±3°C	ΔR/R max. ±(3.0%+0.10Ω) No visible damage	< 50m Ω
Bending strength JISC5201-1: 1998 Clause 4.33	Resistors mounted on a 90mm glass epoxy resin PCB(FR4), bending once 3mm for 10sec, 5mm for WR04	ΔR/R max. ±(1%+0.05Ω) No visual damaged	< 50m Ω
Adhesion JISC5201-1: 19 Clause 4.32	Pressurizing force: 5N, Test time: 10±1sec.	No remarkable damage or removal of the terminations	
Short Time Overload (STOL) JISC5201-1: 1998 Clause 4.13	2.5 times RCWV or max. overload voltage, for 5seconds	ΔR/R max. ±(2.0%+0.10Ω) No visible damage	< 50m Ω
Load life in Humidity JISC5201-1: 1998 Clause 4.24	1000 +48/-0 hours, loaded with RCWV or Vmax in humidity chamber controller at 40°C±2°C and 90~95% relative humidity, 1.5hours on and 0.5 hours off	ΔR/R max. ±(3%+0.10Ω) No visible damage	< 50m Ω
Load life (endurance) JISC5201-1: 1998 Clause 4.25	1000 +48/-0 hours, loaded with RCWV or Vmax in chamber controller 70±2°C, 1.5 hours on and 0.5 hours off	ΔR/R max. ±(3%+0.10Ω) No visible damage	< 50m Ω
Insulation Resistance JISC5201-1: 1998 Clause 4.6	Apply the maximum overload voltage (DC) for 1minute	R≥10GΩ	
Dielectric Withstand Voltage JISC5201-1: 1998 Clause 4.7	Apply the maximum overload voltage (AC) for 1 minute	No breakdown or flashover	

■ For WR Series, WA Series, and WT Series

Test	Procedure / Test Method	Requirements
		Resistor
Electrical Characteristics JISC5201-1: 1998 Clause 4.8	- DC resistance values measurement - Temperature Coefficient of Resistance (T.C.R) Natural resistance change per change in degree centigrade. $\frac{R_2 - R_1}{R_1 (t_2 - t_1)} \times 10^6$ (ppm/°C) $t_1 : 20^\circ\text{C}+5^\circ\text{C}-1^\circ\text{C}$ R1 : Resistance at reference temperature (20°C+5°C/-1°C) R2 : Resistance at test temperature (-55°C or +155°C)	Within the specified tolerance Refer to "QUICK REFERENCE DATA"
Short Time Overload (STOL) JISC5201-1: 1998 Clause 4.13	2.5 times RCWV or max. overload voltage, for 5seconds	$\Delta R/R$ max. $\pm(2.0\%+0.010\Omega)$ WW04X max $\pm(1\%+0.010\Omega)$ No visible damage
Solderability JISC5201-1: 1998 Clause 4.17	Un-mounted chips completely immersed for 2 ± 0.5 second in a SAC solder bath at $235^\circ\text{C}\pm 5^\circ\text{C}$	95% coverage min., good tinning and no visible damage
Resistance to soldering heat (R.S.H) JISC5201-1: 1998 Clause 4.18	Un-mounted chips completely immersed for 10 ± 1 second in a SAC solder bath at $260^\circ\text{C}\pm 5^\circ\text{C}$	no visible damage $\Delta R/R$ max. $\pm(1\%+0.005\Omega)$ WW04X max $\pm(1\%+0.010\Omega)$
Temperature cycling JISC5201-1: 1998 Clause 4.19	30 minutes at $-55^\circ\text{C}\pm 3^\circ\text{C}$, 2~3 minutes at $20^\circ\text{C}+5^\circ\text{C}-1^\circ\text{C}$, 30 minutes at $+155^\circ\text{C}\pm 3^\circ\text{C}$, 2~3 minutes at $20^\circ\text{C}+5^\circ\text{C}-1^\circ\text{C}$, total 5 continuous cycles	no visible damage $\Delta R/R$ max. $\pm(1\%+0.005\Omega)$ WW04X max $\pm(1\%+0.010\Omega)$
Load life (endurance) JISC5201-1: 1998 Clause 4.25	1000 +48/-0 hours, loaded with RCWV or Vmax in chamber controller $70\pm 2^\circ\text{C}$, 1.5 hours on and 0.5 hours off	$\Delta R/R$ max. $\pm(3\%+0.005\Omega)$ WW04X max $\pm(5\%+0.010\Omega)$
Load life in Humidity JISC5201-1: 1998 Clause 4.24	1000 +48/-0 hours, loaded with RCWV or Vmax in humidity chamber controller at $40^\circ\text{C}\pm 2^\circ\text{C}$ and 90~95% relative humidity, 1.5hours on and 0.5 hours off	$\Delta R/R$ max. $\pm(3\%+0.005\Omega)$ WW04X max $\pm(5\%+0.010\Omega)$
Bending strength JISC5201-1: 1998 Clause 4.33	Resistors mounted on a 90mm glass epoxy resin PCB(FR4), bending once 3mm for 10sec, 5mm for WR04	$\Delta R/R$ max. $\pm(1\%+0.005\Omega)$ WW04X max $\pm(1\%+0.010\Omega)$
Adhesion JISC5201-1: 19 Clause 4.32	Pressurizing force: 5N, Test time: 10 ± 1 sec.	No remarkable damage or removal of the terminations
Insulation Resistance JISC5201-1: 1998 Clause 4.6	Apply the maximum overload voltage (DC) for 1minute	$R \geq 10G\Omega$
Dielectric Withstand Voltage JISC5201-1: 1998 Clause 4.7	Apply the maximum overload voltage (AC) for 1 minute	No breakdown or flashover

Chip Resistors

www.passivecomponent.com

Packing on Tape and Reel

Paper Tape Specifications for WR, WF, WW Series and WA, WT Series

Unit: mm

Component Size / Series	W	F	E	P0	ØD
1206, 0805, 0603, 0402, WA06X, WA06T, WA04X, WA04Y, WA04P, WA04T, WA04U, WT04X	8.00 ± 0.30	3.50 ± 0.20	1.75 ± 0.10	4.00 ± 0.10	Ø1.50 ^{+0.1} _{-0.0}
WA06W	12.0 ± 0.10	5.50 ± 0.05			
WR02X	8.00 ± 0.20	3.50 ± 0.05			

Component Size / Series	A	B	P1	T
1206 (3216), WA06X, WA06T	3.60 ± 0.20	2.00 ± 0.20	4.00 ± 0.10	Max. 1.0
0805 (2012)	2.40 ± 0.20	1.65 ± 0.20		0.65 ± 0.05
0603 (1608)	1.90 ± 0.20	1.10 ± 0.20		0.40 ± 0.05
0402 (1005)	1.20 ± 0.10	0.70 ± 0.10	2.00 ± 0.10	Max. 0.6
WA04X, WA04T	2.20 ± 0.20	1.20 ± 0.20	2.00 ± 0.05	
WA04Y, WA04P, WA04U	1.15 ± 0.10	1.15 ± 0.10	2.00 ± 0.05	0.45 ± 0.05
WT04X	3.45 ± 0.2/-0	1.85 ± 0.2/-0	4.00 ± 0.10	0.85 ± 0.05
WA06W	4.20 ± 0.2/-0	1.80 ± 0.2/-0	4.00 ± 0.10	0.65 ± 0.05
WR02X	0.67 ± 0.05	0.37 ± 0.05	2.00 ± 0.05	0.45 ± 0.05

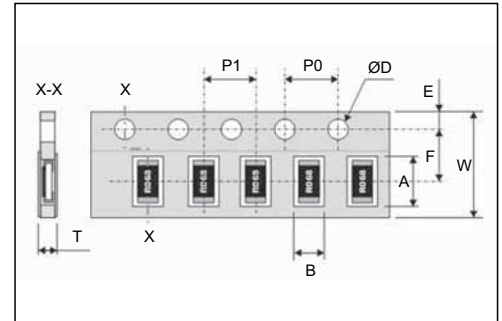

Plastic Tape Specifications for WR, WF, WW Series of Chip-R

Unit: mm

Component Size	2512 (6432)	2010 (5025)	1218 (3248)
A	6.90 ± 0.20	5.50 ± 0.20	3.55 ± 0.30
B	3.60 ± 0.20	2.80 ± 0.20	4.90 ± 0.20
W	12.00 ± 0.30		
F	5.50 ± 0.1		
E	1.75 ± 0.10		
P1	4.00 ± 0.10		
P0	4.00 ± 0.10		
ØD	Ø1.50 ^{+0.1} _{-0.0}		
T	Max. 1.2		

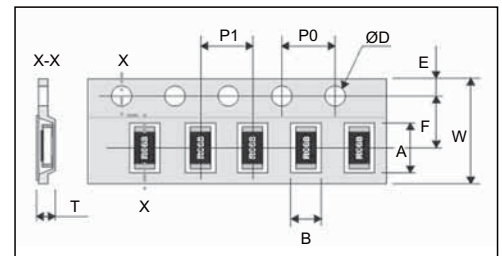

Plastic Tape Specifications for WR, WF, WW Series of Chip-R

Unit: mm

Reel / Tape	A	B	C	D
7" reel for 8mm tape	Ø178.0 ± 0.2	Ø60.0 ± 1.0	13.0 ± 0.2	9.0 ± 0.50
7" reel for 12mm tape				12.4 ± 1.00
10" reel for 8mm tape	Ø254.0 ± 2.0	Ø100.0 ± 1.0	13.0 ± 0.2	9.0 ± 0.50
10" reel for 12mm tape	Ø254.0 ± 2.0	Ø100.0 ± 1.0	13.0 ± 0.2	14.0 ± 0.2
13" reel for 8mm tape	Ø330.0 ± 2.0	Ø100.0 ± 1.0	13.0 ± 0.2	9.0 ± 0.50

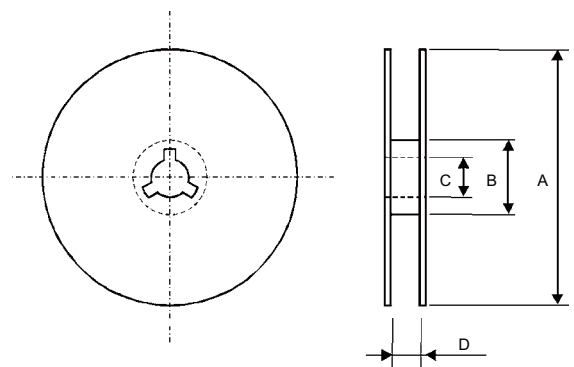

Paper Tape Specifications for WR, WF, WW Series and WA, WT Series

Unit: mm

Component Size / Series	Q'ty per reel	Reel diameter
0603, 0805, 1206	1,000 pcs	4" reel
1210, 1206, 0805, 0603, WA06X, WA06T, WT04X	5,000 pcs	7" reel
0402, WA04X, WA04Y, WA04P, WA04T, WA04U	10,000 pcs	7" reel
0201, 0402	15,000 pcs	7" reel
WA06X, WA06Y	5,000 pcs	7" reel
2512, 2010	4,000 pcs	7" reel
1218	3,000 pcs	10" reel
1206, 0805, 0603, WA06X, WA06T	10,000 pcs	10" reel
0402, WA04X, WA04Y	20,000 pcs	10" reel
2010, 2512	8,000 pcs	10" reel
0402	70,000 pcs	13" reel
WA04X, WA04Y	40,000 pcs	13" reel
1206, 0805, 0603, WA06X	20,000 pcs	13" reel
2010, 2512	16,000 pcs	13" reel

Footprint Design

Footprint Design for WRxx Series, WFxx Series, WWxx Series :

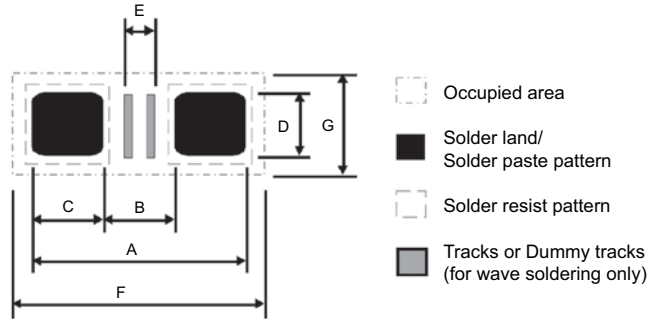

Unit: mm

Size	Reflow Soldering							Processing remarks	Placement Accuracy
	A	B	C	D	E	F	G		
0201	0.75	0.30	0.30	0.30	0.20	1.10	0.50	IR or hot plate soldering	± 0.05
0402	1.50	0.50	0.50	0.60	0.10	1.90	1.00		± 0.15
0603	2.10	0.90	0.60	0.90	0.50	2.35	1.45		± 0.25
0805	2.60	1.20	0.70	1.30	0.75	2.85	1.90		± 0.25
1206	3.80	2.00	0.90	1.60	1.60	4.05	2.25		± 0.25
1218	3.80	2.00	0.90	4.80	1.40	4.20	5.50		± 0.25
2010	5.60	3.80	0.90	2.80	3.40	5.85	3.15		± 0.25
2512	7.00	3.80	1.60	3.50	3.40	7.25	3.85		± 0.25
Size	Wave Soldering							Processing number & Dimensions of dummy tracks	Placement Accuracy
	A	B	C	D	E	F	G		
0603	2.70	0.90	0.90	0.80	0.15	3.40	1.90	1 x (0.15 x 0.80)	± 0.25
0805	3.40	1.30	1.05	1.30	0.20	4.30	2.70	1 x (0.20 x 1.30)	± 0.25
1206	4.80	2.30	1.25	1.70	1.25	5.90	3.20	3 x (0.25 x 1.70)	± 0.25
1218	4.80	2.30	1.25	4.80	1.30	5.90	5.60	3 x (0.25 x 4.80)	± 0.25
2010	6.30	3.50	1.40	2.50	3.00	7.00	3.60	3 x (0.75 x 2.50)	± 0.25
2512	8.50	4.50	2.00	3.20	3.00	9.00	4.30	3 x (1.00 x 3.20)	± 0.25

Footprint Design for Array Resistor/Attenuator :

Unit: mm

Symbol	0603*4 array	0402*4 array	WA04Y, WA04P	WA06W
A	2.85+0.10/-0.05	1.80+0.15/-0.05	1.20 ± 0.05	3.85+0.20/-0.05
B	0.45 ± 0.05	0.30 ± 0.05	0.40 +0/-0.05	0.28 +0/-0.05
D	0.80 ± 0.10	0.50 ± 0.1	0.50 ± 0.05	1.00+0.10/-0.20
P	0.80	0.50	0.65	0.50
F	3.10 ± 0.30	2.00 +0.40/-0.20	1.50 +0.20/-0.10	3.20 ± 0.40

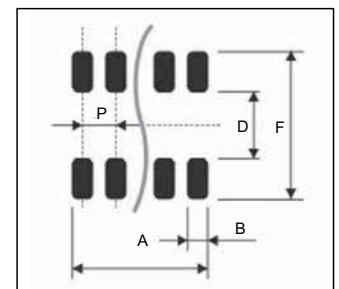

Footprint Design for 10P8R Network Resistor :

Unit: mm

Symbol	WT04X
W1	0.50 ± 0.05
W2	0.35 ± 0.05
H2	0.80 ± 0.10
P1	0.70 ± 0.05
P2	0.65 ± 0.05
A	3.20 ± 0.10
F	2.80 + 0.40 / - 0.20

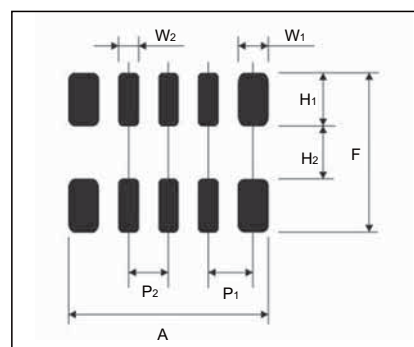

Chip Resistors

www.passivecomponent.com

Storage and Handling Conditions:

1. Products are recommended to be used up within one year. Check solderability in case shelf life extension is needed.
2. To store products with following condition:
 - Temperature : 5 to 40°C
 - Humidity : 20 to 70% relative humidity
3. Caution:
 - a. Don't store products in a corrosive environment such as sulfide, chloride gas, or acid. It may cause oxidation of electrode, which easily be resulted in poor soldering.
 - b. To store products on the shelf and avoid exposure to moisture.
 - c. Don't expose products to excessive shock, vibration, direct sunlight and so on.

Recommendation of Soldering Profile:

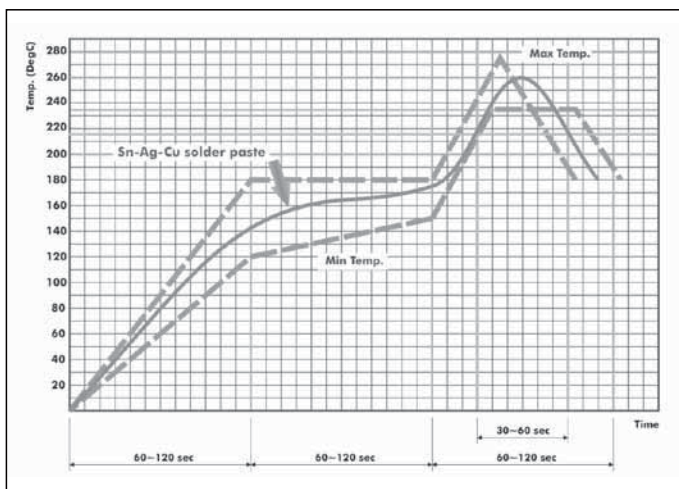

Figure. IR reflow soldering profile for SMT process with SnAgCu series solder paste.

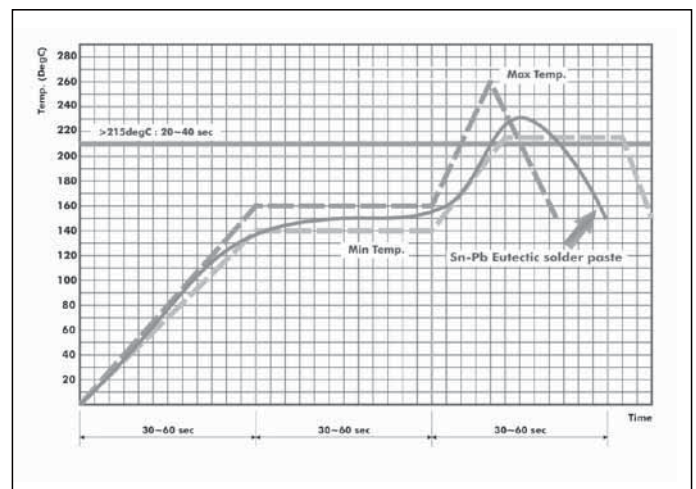

Figure. IR reflow soldering profile for SMT process with eutectic SnPb solder paste.

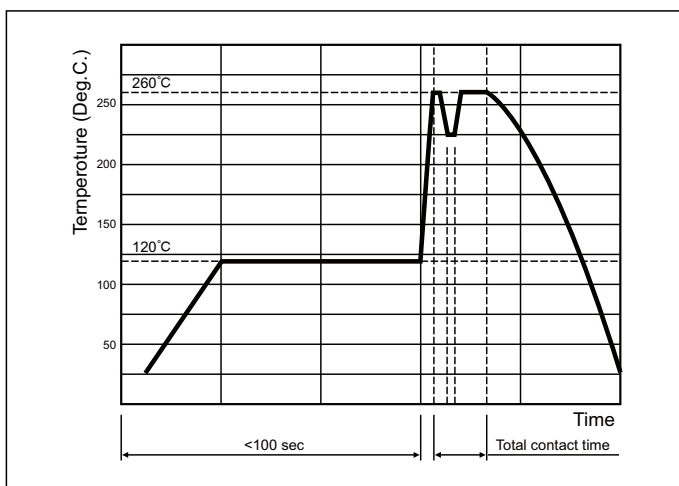

Figure. Wave soldering

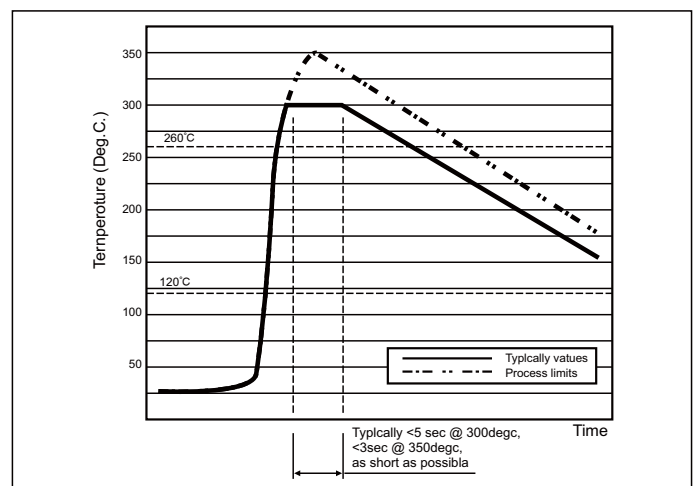

Figure. Manual soldering (soldering gun)

PLAN & MEMO

A series of horizontal dashed lines for writing.

Yang-Mei Plant / Sales Office

Walsin Technology Corporation
556-1, Kao-Shi Road, Yang-Mei,
Tao-Yuan, Taiwan
Tel: +886-3-475-8711
Fax: +886-3-475-7130
Email: info@passivecomponent.com

Kaohsiung Plant, Taiwan

Walsin Technology Corporation
1st, West 13 Street, K.E.P.Z.
Kaohsiung, Taiwan
Tel: +886-7-821-8171
Fax: +886-7-813-1661
Email: info@passivecomponent.com

China - Dalang Plant / Sales Office

Dongguan Walsin Tech. Electronics CO., Ltd.
Xiniupo Administrative Zone,
Dalang Town, Dongguan City,
Guangdong Province 523799
Tel: +86-769-83115168
Fax: +86-769-83115188
Email: stlin@passivecomponent.com

China - Suzhou Plant / Sales Office

Suzhou Walsin Technology Electronics Co., Ltd.
No. 369, Changyan Street,
Suzhou Industrial Park,
Jiangsu Province 215126
Tel: +86-512-628-36888
Fax: +86-512-628-37888
Email: lewisliang@passivecomponent.com

China - Guangzhou Plant / Sales Office

Pan Overseas (Guangzhou) Electronic Co., Ltd.
No. 277, Hong Ming Road, Eastern Section,
Guangzhou Economic and Technology
Development Zone, China
Tel: +86-20-8223-7476
Fax: +86-20-8223-7475
Email: info@passivecomponent.com

China - Tianjin Sales Office

Walsin Technology Corporation (Tian Jin)
No.51 The Ninth Avenue, Tianjin Technological
Development Area(TEDA) Tianjin 300457
Tel: +86-22-59820009
Fax: +86-22-59820008
Email: Johnsorwang@passivecomponent.com

Germany - Munich Sales Office

Walsin Technology Corporation Europe
Stefan-George-Ring 29, 81929 Munich, Germany
Tel: +49-(0)89-9308-6475
Fax: +49-(0)89-9308-6464
Email: aw@passivecomponent.com

Singapore - Sales Office

Walsin Electronics (S) Pte. Ltd.
2 Jurong East Street 21,
#04-33F IMM Building,
Singapore 609601
Tel: +65-6794-3600
Fax: +65-6861-3381
Email: peterchew@sg.passivecomponent.com

United States - West Coast Sales Office

Walsin Technology Corporation, USA
39500 Stevenson Place Suite 101,
Fremont, CA 94539, USA
Tel: +1-510-713-1190
Email: leeku@passivecomponent.com

JAPAN - R&D / Sales Office

Walsin Technology Corporation (Japan)
D-442, KSP R&D Business Park Building,
3-2-1 Sakado Takatsuku, Kawasaki City,
Kanagawa 213-0012, Japan
Tel: +81-44-829-4626
Fax: +81-44-829-4723
Nitsuko Electronic Corporation
Tel: +81-44-820-1570
Fax: +81-44-820-1571
Email: sakanotsu@nitsuko-ele.co.jp



Yang-Mei

Walsin Technology Corporation
566-1, Kao-Shi Road, Yang-Mei,
Tao-Yuan, Taiwan
Tel: 886-3-475-8711
Fax: 886-3-475-7129 475-7130
E-mail: info@passivecomponent.com

Kaohsiung

Walsin Technology Corporation
1st, West 13 Street, K.E.P.Z.
Kaohsiung, Taiwan
Tel: 886-7-821-8171
Fax: 886-7-813-1661
E-mail: info@passivecomponent.com